

SECTION BR
BRAKE SYSTEM

A
B
C
D
E

CONTENTS

PRECAUTION	3	PERIODIC MAINTENANCE	12
PRECAUTIONS	3	BRAKE PEDAL	12
Precaution for Supplemental Restraint System (SRS) "AIR BAG" and "SEAT BELT PRE-TENSIONER"	3	Inspection	12
Precaution for Procedure without Cowl Top Cover.....	3	Adjustment	12
Precaution for Brake System	3	BRAKE FLUID	14
PREPARATION	5	Inspection	14
PREPARATION	5	Drain and Refill	14
Special Service Tool	5	Bleeding Brake System	15
Commercial Service Tool	5	FRONT DISC BRAKE	16
SYMPTOM DIAGNOSIS	6	BRAKE PAD	16
NOISE, VIBRATION AND HARSHNESS (NVH) TROUBLESHOOTING	6	BRAKE PAD : Inspection	16
NVH Troubleshooting Chart	6	BRAKE PAD : Brake Burnishing	16
BASIC INSPECTION	7	DISC BRAKE ROTOR	16
BRAKE MASTER CYLINDER	7	DISC BRAKE ROTOR : Inspection	16
Inspection	7	DISC BRAKE ROTOR : Brake Burnishing	17
BRAKE BOOSTER	8	REAR DISC BRAKE	18
Inspection	8	BRAKE PAD	18
VACUUM LINES	9	BRAKE PAD : Inspection	18
Inspection - Vacuum Hose Without Check Valve.....	9	BRAKE PAD : Brake Burnishing	18
Inspection - Vacuum Hose With Check Valve	9	DISC BRAKE ROTOR	18
FRONT DISC BRAKE	10	DISC BRAKE ROTOR : Inspection	18
DISC BRAKE ROTOR	10	DISC BRAKE ROTOR : Brake Burnishing	19
DISC BRAKE ROTOR : Inspection	10	REMOVAL AND INSTALLATION	20
REAR DISC BRAKE	11	BRAKE PEDAL	20
DISC BRAKE ROTOR	11	Exploded View	20
DISC BRAKE ROTOR : Inspection	11	Removal and Installation	20
		BRAKE PIPING	22
		FRONT	22
		FRONT : Exploded View	22
		FRONT : Hydraulic Piping	24
		FRONT : Removal and Installation	25

BR
G
H
I
J
K
L
M
N
O
P

REAR	26	BRAKE CALIPER ASSEMBLY	43
REAR : Exploded View	26	BRAKE CALIPER ASSEMBLY : Exploded View ...	44
REAR : Hydraulic Piping	27	BRAKE CALIPER ASSEMBLY : Removal and In-	
REAR : Removal and Installation	28	stallation	44
BRAKE MASTER CYLINDER	30	DISC BRAKE ROTOR	45
Exploded View	30	DISC BRAKE ROTOR : Exploded View	46
Removal and Installation	30	DISC BRAKE ROTOR : Removal and Installation...	46
BRAKE BOOSTER	32	UNIT DISASSEMBLY AND ASSEMBLY ...	47
Exploded View	32	FRONT DISC BRAKE	47
Removal and installation	32	Exploded View	47
VACUUM LINES	34	Disassembly and Assembly	47
Exploded View	34	REAR DISC BRAKE	50
Removal and Installation	35	BRAKE CALIPER ASSEMBLY	50
FRONT DISC BRAKE	37	BRAKE CALIPER ASSEMBLY : Exploded View ...	50
BRAKE PAD	37	BRAKE CALIPER ASSEMBLY : Disassembly and	
BRAKE PAD : Exploded View	37	Assembly	50
BRAKE PAD : Removal and Installation	37	SERVICE DATA AND SPECIFICATIONS	
BRAKE CALIPER ASSEMBLY	38	(SDS)	53
BRAKE CALIPER ASSEMBLY : Exploded View ...	39	SERVICE DATA AND SPECIFICATIONS	
BRAKE CALIPER ASSEMBLY : Removal and In-		(SDS)	53
stallation	39	General Specifications	53
DISC BRAKE ROTOR	40	Brake Pedal	53
DISC BRAKE ROTOR : Exploded View	41	Check Valve - Vacuum Hose Without Check Valve	
DISC BRAKE ROTOR : Removal and Installation..	41	... 54	
REAR DISC BRAKE	42	Check Valve - Vacuum Hose With Check Valve ...	54
BRAKE PAD	42	Brake Booster	54
BRAKE PAD : Exploded View	42	Front Disc Brake	55
BRAKE PAD : Removal and Installation	42	Rear Disc Brake	55

PRECAUTIONS

< PRECAUTION >

PRECAUTION

PRECAUTIONS

Precaution for Supplemental Restraint System (SRS) "AIR BAG" and "SEAT BELT PRE-TENSIONER"

INFOID:000000012227790

The Supplemental Restraint System such as "AIR BAG" and "SEAT BELT PRE-TENSIONER", used along with a front seat belt, helps to reduce the risk or severity of injury to the driver and front passenger for certain types of collision. Information necessary to service the system safely is included in the SR and SB section of this Service Manual.

WARNING:

- To avoid rendering the SRS inoperative, which could increase the risk of personal injury or death in the event of a collision which would result in air bag inflation, all maintenance must be performed by an authorized NISSAN/INFINITI dealer.
- Improper maintenance, including incorrect removal and installation of the SRS, can lead to personal injury caused by unintentional activation of the system. For removal of Spiral Cable and Air Bag Module, see the SR section.
- Do not use electrical test equipment on any circuit related to the SRS unless instructed to in this Service Manual. SRS wiring harnesses can be identified by yellow and/or orange harnesses or harness connectors.

PRECAUTIONS WHEN USING POWER TOOLS (AIR OR ELECTRIC) AND HAMMERS

WARNING:

- When working near the Airbag Diagnosis Sensor Unit or other Airbag System sensors with the Ignition ON or engine running, DO NOT use air or electric power tools or strike near the sensor(s) with a hammer. Heavy vibration could activate the sensor(s) and deploy the air bag(s), possibly causing serious injury.
- When using air or electric power tools or hammers, always switch the Ignition OFF, disconnect the battery and wait at least three minutes before performing any service.

Precaution for Procedure without Cowl Top Cover

INFOID:000000012227791

When performing the procedure after removing cowl top cover, cover the lower end of windshield with urethane, etc. to prevent damage to windshield.

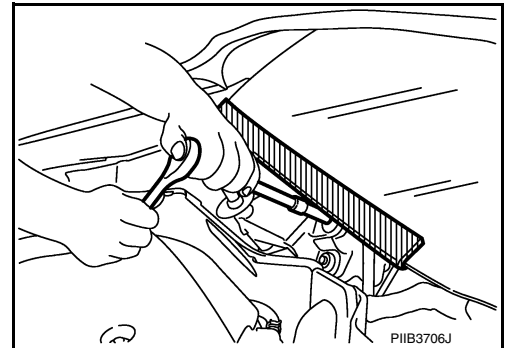

Precaution for Brake System

INFOID:000000012227793

WARNING:

Clean any dust from the front brake and rear brake using a vacuum dust collector. Do not blow by compressed air.

- Brake fluid use refer to [BR-14. "Drain and Refill"](#).
- Do not reuse drained brake fluid.
- Do not spill or splash brake fluid on painted surfaces. Brake fluid may seriously damage paint. Wipe it off immediately and wash with water if it gets on a painted surface.
- Always clean with new brake fluid when cleaning the master cylinder, brake caliper and other components.
- Do not use mineral oils such as gasoline or light oil to clean. They may damage rubber parts and cause improper operation.
- Always loosen the brake tube flare nut with a flare nut wrench.

PRECAUTIONS

< PRECAUTION >

- Tighten the brake tube flare nut to the specified torque with crow-foot (A) and torque wrench (B).
- Always confirm the specified tightening torque when installing the brake pipes.
- Turn the ignition switch OFF and disconnect the ABS actuator and electric unit (control unit) connector or the battery negative terminal before performing the work.
- Always connect the battery terminal when moving the vehicle.
- Check that no brake fluid leak is present after replacing the parts.
- Check for bends, cracks and damage to the brake pedal. Adjust brake pedal if it is outside the standard value.
- Burnish the brake contact surfaces after refinishing or replacing rotors, after replacing pads, or if a soft pedal occurs at very low mileage.
- Front disc brake: refer to [BR-17, "DISC BRAKE ROTOR : Brake Burnishing"](#).
- Rear disc brake: refer to [BR-19, "DISC BRAKE ROTOR : Brake Burnishing"](#).

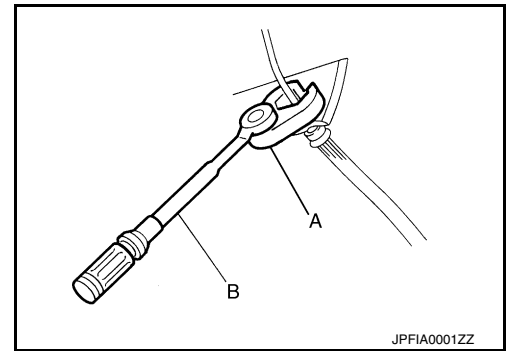

PREPARATION

< PREPARATION >

PREPARATION

PREPARATION

Special Service Tool

INFOID:000000011933941

The actual shape of the tools may differ from those illustrated here.

Tool number (TechMate No.) Tool name	Description
— (J-46532) Brake height tool	Measuring brake pedal height
38-PFM92 (—) Pro-Cut™ PFM Series Lathe	Refinishing rotors

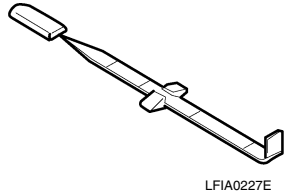

LFIA0227E

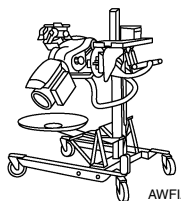

AWFIA1169ZZ

Commercial Service Tool

INFOID:000000011933942

Tool name	Description
1. Flare nut crowfoot 2. Torque wrench	Tightening brake tube flare nuts a: 10mm (0.39 in)/12mm (0.47 in)
Power tool	Loosening nuts, screws and bolts

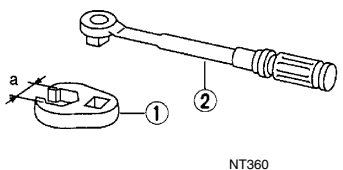

NT360

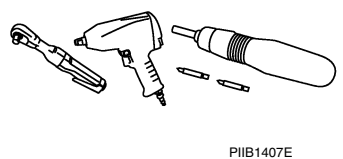

PIIB1407E

NOISE, VIBRATION AND HARSHNESS (NVH) TROUBLESHOOTING

< SYMPTOM DIAGNOSIS >

SYMPTOM DIAGNOSIS

NOISE, VIBRATION AND HARSHNESS (NVH) TROUBLESHOOTING

NVH Troubleshooting Chart

INFOID:0000000012227714

Use the chart below to find the cause of the symptom. If necessary, repair or replace these parts.

Symptom		BRAKE	Possible cause and SUSPECTED PARTS													Reference page						
			Brake pads or linings damaged	Brake pads or linings uneven wear	Shims damaged	Disc brake rotor imbalance	Disc brake rotor damage	Disc brake rotor runout	Disc brake rotor deformation	Disc brake rotor deflection	Disc brake rotor rust	Disc brake rotor thickness variation	Disc brake out of round	AXLE AND SUSPENSION	TIRE		WHEEL	DRIVE SHAFT	STEERING			
	Noise		x	x	x									x							BR-16, BR-18	
	Shake					x																BR-16, BR-18
	Shimmy, Judder					x	x	x	x	x		x	x	x	x	x						BR-16, BR-18
																						BR-18, BR-10, BR-11
																						BR-18, BR-10, BR-11
																						BR-16, BR-18
																						BR-16, BR-18
																						BR-16, BR-18
																						BR-18, BR-10, BR-11
																						BR-10, BR-11
																						FAX-5, RAX-4, FSU-5, RSU-4
																						WT-62
																						WT-62
																						FAX-5
																						ST-28

x: Applicable

BRAKE MASTER CYLINDER

< BASIC INSPECTION >

BASIC INSPECTION

BRAKE MASTER CYLINDER

Inspection

INFOID:0000000012227400

Check for brake fluid leaks at the following areas:

- Master cylinder mounting face
- Reservoir tank mounting face
- Brake tube and brake tube connections
- Brake hose and brake hose connections

If any brake fluid leak is found, repair as necessary.

A

B

C

D

E

BR

G

H

I

J

K

L

M

N

O

P

BRAKE BOOSTER

< BASIC INSPECTION >

BRAKE BOOSTER

Inspection

INFOID:000000012227401

Operation

Depress the brake pedal several times at five-second intervals with the engine stopped. Start the engine with the brake pedal fully depressed. Check that the clearance between brake pedal and dash lower panel decreases.

NOTE:

A slight impact with a small click may be felt on the pedal when the brake pedal is fully depressed. This is normal brake system operation.

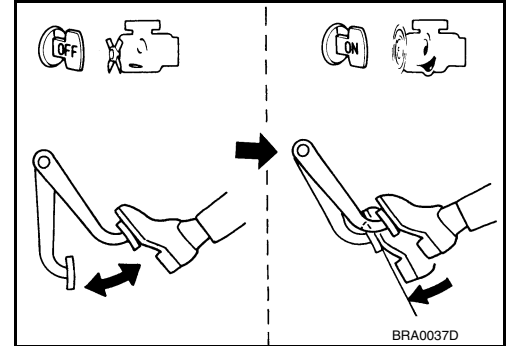

Vacuum Inspection

Idle the engine for one minute to apply vacuum to the brake booster. Stop the engine. Depress the brake pedal several times at five-second intervals until the accumulated vacuum is released to atmospheric pressure. Check that the clearance between brake pedal and dash lower panel gradually increases (A → B → C) each time the brake pedal is depressed during this operation.

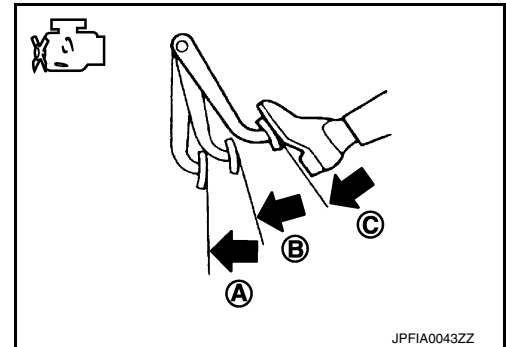

Depress the brake pedal with the engine running. Then stop the engine while holding down the brake pedal. Check that the brake pedal stroke does not change after holding down the brake pedal for 30 seconds or more.

NOTE:

A slight impact with a small click may be felt on the pedal when the brake pedal is fully depressed. This is normal brake system operation.

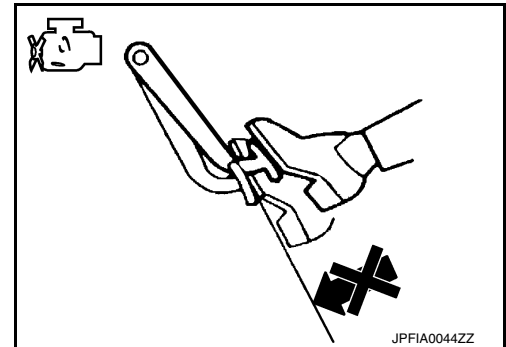

VACUUM LINES

< BASIC INSPECTION >

VACUUM LINES

Inspection - Vacuum Hose Without Check Valve

INFOID:000000013042405

CHECK VALVE INSPECTION

Air-tightness Inspection

Use a suitable tool to check. Connect to brake booster side of check valve.

Check valve specification

: Refer to [BR-54, "Check Valve - Vacuum Hose Without Check Valve"](#).

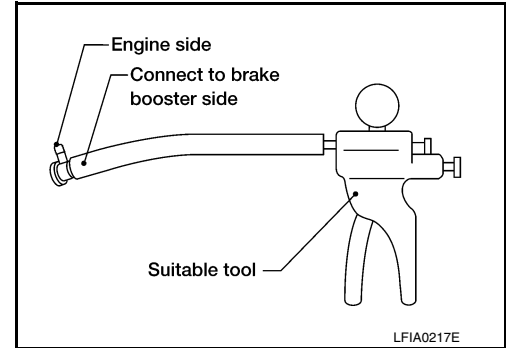

Inspection - Vacuum Hose With Check Valve

INFOID:000000013089365

CHECK VALVE INSPECTION

Air-tightness Inspection

- Connect a suitable tool at each end of the vacuum hose to inspect the check valve operation.

Vacuum applied at booster end

: Refer to [BR-54, "Check Valve - Vacuum Hose With Check Valve"](#).

Vacuum applied at intake manifold end

: Refer to [BR-54, "Check Valve - Vacuum Hose With Check Valve"](#).

- Replace the vacuum hose with check valve if out of specification.

FRONT DISC BRAKE

< BASIC INSPECTION >

FRONT DISC BRAKE

DISC BRAKE ROTOR

DISC BRAKE ROTOR : Inspection

INFOID:000000012227402

INSPECTION

Uneven wear

Check for uneven wear of the disc brake rotor using a micrometer.
Replace the disc brake rotor if the thickness is below the wear limit.
Refer to [BR-41, "DISC BRAKE ROTOR : Removal and Installation"](#).

Thickness variation : Refer to [BR-55, "Front Disc Brake"](#).
(measured at 8 positions)

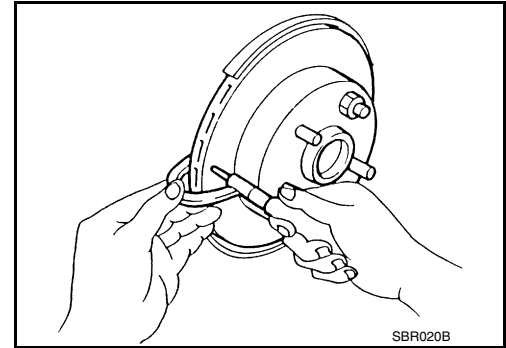

REAR DISC BRAKE

< BASIC INSPECTION >

REAR DISC BRAKE

DISC BRAKE ROTOR

DISC BRAKE ROTOR : Inspection

INFOID:000000012227403

INSPECTION

Uneven wear

Check for uneven wear of the disc brake rotor using a micrometer. Replace the disc brake rotor if the thickness is below the wear limit. Refer to [BR-46, "DISC BRAKE ROTOR : Removal and Installation"](#).

Thickness variation : Refer to [BR-55, "Rear Disc Brake"](#).
(measured at 8 positions)

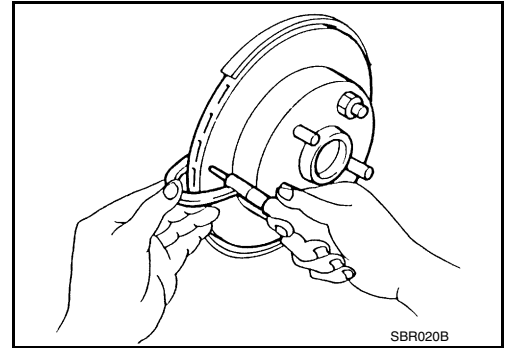

A

B

C

D

E

BR

G

H

I

J

K

L

M

N

O

P

BRAKE PEDAL

< PERIODIC MAINTENANCE >

PERIODIC MAINTENANCE

BRAKE PEDAL

Inspection

INFOID:000000012227409

BRAKE PEDAL HEIGHT

Check the brake pedal height (H) between the dash lower panel (2) and the brake pedal upper surface.

CAUTION:

Check the brake pedal height with the floor trim removed.

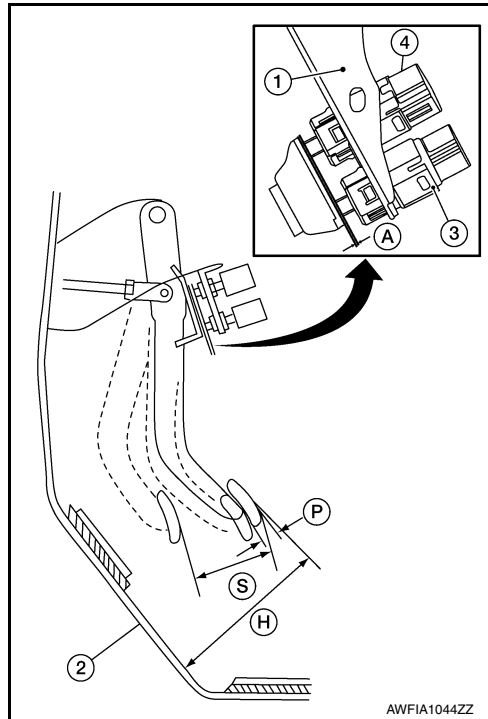

Brake pedal height (H) from dash lower panel (2)	Refer to BR-53, "Brake Pedal" .
Clearance (A) between brake pedal bracket (1), stop lamp switch (3) and brake pedal position switch (4) contact ends	Refer to BR-53, "Brake Pedal" .
Brake pedal full stroke (S)	Refer to BR-53, "Brake Pedal" .
Brake pedal play (P)	Refer to BR-53, "Brake Pedal" .

Adjustment

INFOID:000000012227410

BRAKE PEDAL HEIGHT

1. Remove instrument lower panel LH. Refer to [IP-23, "Removal and Installation"](#).
2. Disconnect harness connectors from the stop lamp switch and brake pedal position switch.
3. Turn stop lamp switch and brake pedal position switch 45° counterclockwise.
4. Loosen input rod lock nut (1).

CAUTION:

- Check the height with the floor trim removed.
- The threaded end of the input rod (2) must project to the inner side (L) of the clevis (3).

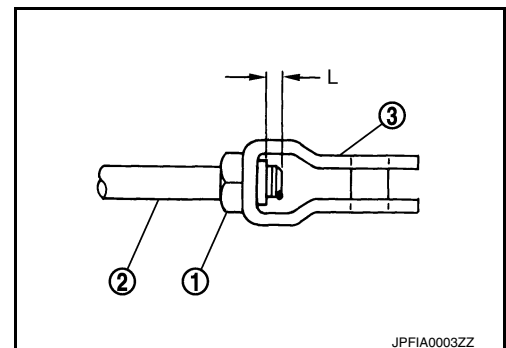

BRAKE PEDAL

< PERIODIC MAINTENANCE >

5. Adjust brake pedal height to specification. Refer to [BR-53, "Brake Pedal"](#).
6. Tighten input rod lock nut to specification. Refer to [BR-20, "Exploded View"](#).
7. Turn stop lamp switch and brake pedal position switch 45° clockwise.
8. Connect harness connectors to stop lamp switch and brake pedal position switch.
9. Check brake pedal for smooth operation.

CAUTION:

The stop lamp must turn off when the brake pedal is released.

10. Install instrument lower panel LH. Refer to [IP-23, "Removal and Installation"](#).

STOP LAMP SWITCH AND BRAKE PEDAL POSITION SWITCH

1. Remove instrument lower panel LH. Refer to [IP-23, "Removal and Installation"](#).
2. Disconnect the harness connectors from the stop lamp switch and brake pedal position switch.
3. Turn the stop lamp switch and brake pedal position switch 45° counterclockwise.
4. With threaded ends of stop lamp switch (1) and brake pedal position switch (2) contacting pedal bracket (3), turn switches 45° clockwise to lock in place. Check that both stop lamp switch and brake pedal position switch contact ends to brake pedal bracket clearance (A) are within specification.

CAUTION:

- Make sure that the clearance between the brake pedal bracket, stop lamp switch and the brake pedal position switch contact ends are within specification.
- The stop lamp must turn off when the brake pedal is released.

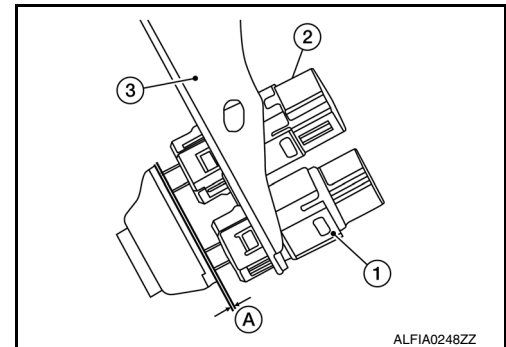

Clearance (A) : Refer to [BR-53, "Brake Pedal"](#).

5. Connect harness connectors to stop lamp switch and brake pedal position switch.
6. Install instrument lower panel LH. Refer to [IP-23, "Removal and Installation"](#).

BRAKE FLUID

< PERIODIC MAINTENANCE >

BRAKE FLUID

Inspection

INFOID:000000012227411

BRAKE FLUID LEVEL

- Make sure that the brake fluid level in the reservoir tank is between the MAX and MIN lines.
- Visually check around the reservoir tank for brake fluid leaks.
- If the brake fluid level is excessively low, check the brake system for leaks.
- If brake warning lamp remains illuminated after parking brake pedal is released, check the brake system for brake fluid leaks.

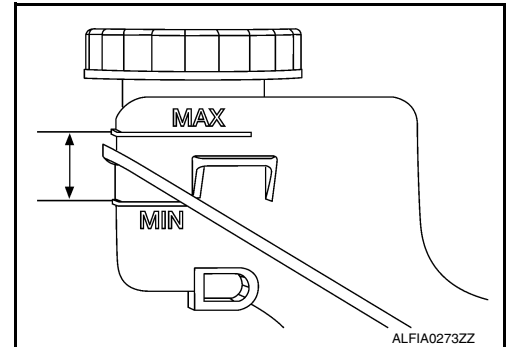

BRAKE LINE

1. Check brake line (tubes and hoses) for cracks, deterioration or other damage. Replace any damaged parts.
2. Check for brake fluid leaks by fully depressing brake pedal while engine is running.

CAUTION:

If brake fluid leak occurs around joints, retighten or replace damaged parts as necessary.

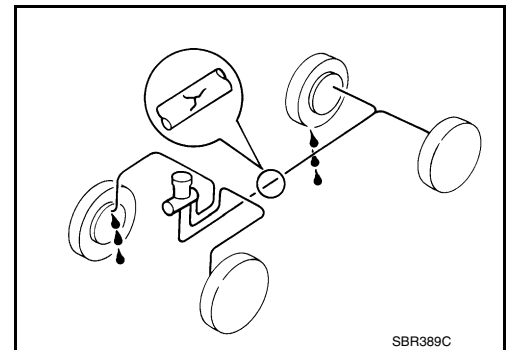

Drain and Refill

INFOID:000000012227412

CAUTION:

- Do not spill or splash brake fluid on painted surfaces. Brake fluid may damage paint. If brake fluid is splashed on painted areas, wash it away with water immediately.
- Refill brake system with new brake fluid. Refer to [MA-16, "FOR USA AND CANADA : Fluids and Lubricants"](#) (for United States and Canada) or [MA-17, "FOR MEXICO : Fluids and Lubricants"](#) (for Mexico).
- Do not reuse drained brake fluid.

DRAINING

1. Turn ignition switch OFF and disconnect the harness connector from the ABS actuator and electric unit (control unit) or negative battery terminal. Refer to [PG-101, "Exploded View"](#).
2. Connect a vinyl tube to bleeder valve.
3. Depress brake pedal, loosen bleeder valve, and gradually remove brake fluid.

CAUTION:

Do not allow reservoir tank to empty as this may cause damage to master cylinder internal components.

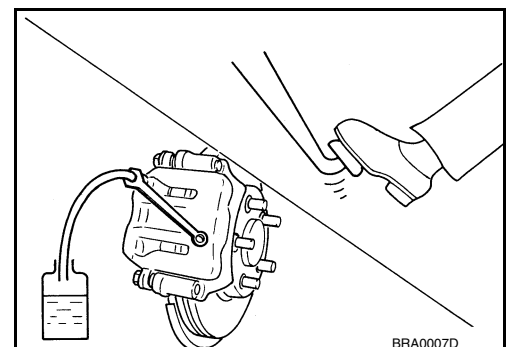

REFILLING

BRAKE FLUID

< PERIODIC MAINTENANCE >

1. Make sure no foreign material is in the reservoir tank and refill with new brake fluid.

CAUTION:

Do not reuse drained brake fluid.

2. Refill the brake system as follows:
 - Depress the brake pedal.
 - Loosen bleeder valve.
 - Slowly depress brake pedal to 2/3 of the brake pedal full stroke.
 - Tighten bleeder valve.
 - Release brake pedal.

Repeat this operation in intervals of two or three seconds until all old brake fluid is discharged. Add new brake fluid to reservoir tank frequently.

CAUTION:

Do not allow reservoir tank to empty as this may cause damage to master cylinder internal components.

3. Bleed the air out of the brake hydraulic system. Refer to [BR-15, "Bleeding Brake System"](#).

Bleeding Brake System

INFOID:000000012227413

CAUTION:

- Do not spill or splash brake fluid on painted surface. Brake fluid may damage paint. If brake fluid is splashed on painted surface, wash away with water immediately.
- While bleeding, pay attention to brake fluid level.
- Do not allow reservoir tank to empty as this may cause damage to master cylinder internal components.
- Before working, disconnect the harness connector from the ABS actuator and electric unit (control unit) or negative battery terminal. Refer to [PG-105, "Exploded View"](#).

1. Turn ignition switch OFF and disconnect the harness connector from the ABS actuator and electric unit (control unit) or negative battery terminal. Refer to [PG-105, "Exploded View"](#).
2. Connect a vinyl tube to front (RH) brake caliper bleeder valve.
3. Fully depress brake pedal 4 or 5 times.
4. With brake pedal depressed, loosen bleeder valve to bleed air in brake line, and then tighten it immediately.
5. Repeat steps 3 and 4 until all of the air is out of the brake line.
6. Tighten the bleeder valve to the specified torque. Refer to [BR-39, "BRAKE CALIPER ASSEMBLY : Exploded View"](#) (FRONT DISC BRAKE) or [BR-44, "BRAKE CALIPER ASSEMBLY : Exploded View"](#) (REAR DISC BRAKE).
7. Repeat steps 2 through 6 with reservoir tank filled at least halfway. Bleed the air in the following order from the front (RH), front (LH), rear (RH), rear (LH).

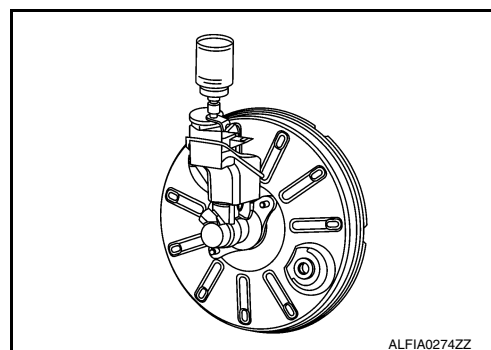

A
B
C
D
E
BR
G
H
I
J
K
L
M
N
O
P

FRONT DISC BRAKE

< PERIODIC MAINTENANCE >

FRONT DISC BRAKE BRAKE PAD

BRAKE PAD : Inspection

INFOID:000000012227414

INSPECTION

Check brake pad wear thickness from an inspection hole on cylinder body. Check using a scale if necessary.

Wear thickness : Refer to [BR-55, "Front Disc Brake"](#).

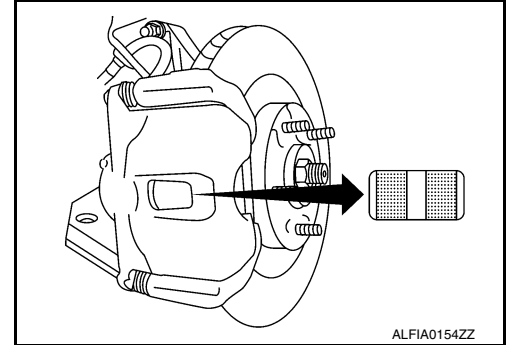

BRAKE PAD : Brake Burnishing

INFOID:000000012227415

CAUTION:

- Burnish contact surfaces between brake pads and disc brake rotor according to the following procedure after refinishing the disc brake rotor, replacing brake pads or if a soft pedal occurs at very low mileage.
- Be careful of vehicle speed. Brakes do not operate firmly/securely until pads and disc brake rotor are securely seated.
- Only perform this procedure under safe road and traffic conditions. Use extreme caution.

1. Drive vehicle on straight, flat road.
2. Depress brake pedal until vehicle stops.
3. Release brake pedal for a few minutes to allow brake components to cool.
4. Repeat steps 1 through 3 until pad and disc brake rotor are securely seated.

DISC BRAKE ROTOR

DISC BRAKE ROTOR : Inspection

INFOID:000000012227416

INSPECTION

Appearance

Check surface of disc brake rotor for uneven wear, cracks, or damage. Replace it if necessary. Refer to [BR-41, "DISC BRAKE ROTOR : Removal and Installation"](#).

RUNOUT

1. Check wheel bearing axial end play before inspection. Refer to [FAX-37, "Wheel Bearing"](#).
2. Secure disc brake rotor to wheel hub and bearing with wheel nuts at two wheel nut locations.
3. Measure runout using a dial gauge 10 mm (0.39 in) from disc brake rotor edge.

Runout (with it attached to the vehicle) : Refer to [BR-55, "Front Disc Brake"](#)

4. Find installation position with a minimum runout by shifting the disc brake rotor-to-wheel hub and bearing installation position by one hole at a time if runout exceeds limit value.
5. Refinish disc brake rotor if runout is outside limit even after performing above operation. When refinishing, use Tool.

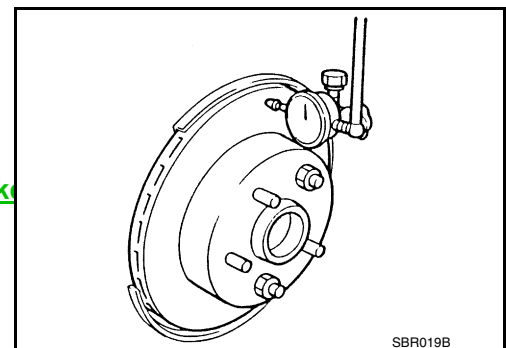

FRONT DISC BRAKE

< PERIODIC MAINTENANCE >

Tool number : 38-PFM92 (—)

CAUTION:

- Check in advance that the thickness of the disc brake rotor is wear thickness + 0.3 mm (0.012 in) or more.
- If the thickness is less than wear thickness + 0.3 mm (0.012 in), replace the disc brake rotor.

Wear thickness : Refer to [BR-55, "Front Disc Brake"](#).

THICKNESS

Check thickness of disc brake rotor using a micrometer. Replace disc brake rotor if thickness is below the wear limit.

Wear thickness : Refer to [BR-55, "Front Disc Brake"](#).

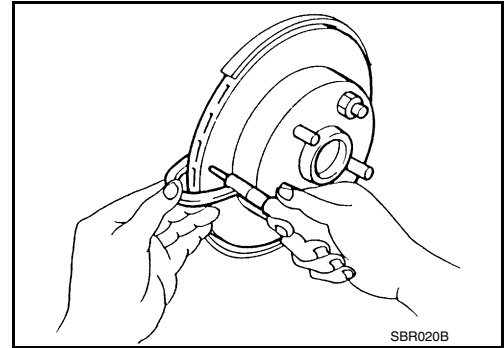

DISC BRAKE ROTOR : Brake Burnishing

INFOID:000000012227417

CAUTION:

- Burnish contact surfaces between brake pads and disc brake rotor according to the following procedure after refinishing the disc brake rotor, replacing brake pads or if a soft pedal occurs at very low mileage.
 - Be careful of vehicle speed. Brakes do not operate firmly/securely until pads and disc brake rotor are securely seated.
 - Only perform this procedure under safe road and traffic conditions. Use extreme caution.
1. Drive vehicle on straight, flat road.
 2. Depress brake pedal until vehicle stops.
 3. Release brake pedal for a few minutes to allow brake components to cool.
 4. Repeat steps 1 through 3 until pad and disc brake rotor are securely seated.

REAR DISC BRAKE

< PERIODIC MAINTENANCE >

REAR DISC BRAKE BRAKE PAD

BRAKE PAD : Inspection

INFOID:000000012227418

INSPECTION

Check brake pad wear thickness from an inspection hole on cylinder body. Check using a scale if necessary.

Wear thickness : Refer to [BR-55, "Rear Disc Brake"](#).

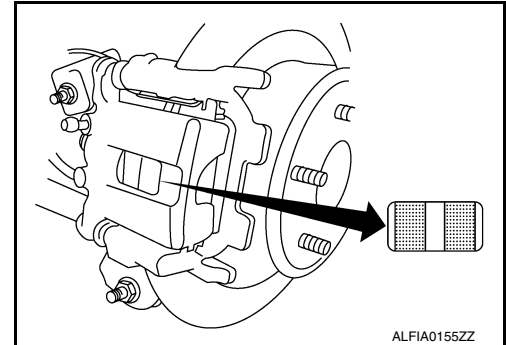

BRAKE PAD : Brake Burnishing

INFOID:000000012227419

CAUTION:

- Burnish contact surfaces between brake pads and disc brake rotor according to the following procedure after refinishing the disc brake rotor, replacing brake pads or if a soft pedal occurs at very low mileage.
 - Be careful of vehicle speed. Brakes do not operate firmly/securely until pads and disc brake rotor are securely seated.
 - Only perform this procedure under safe road and traffic conditions. Use extreme caution.
1. Drive vehicle on straight, flat road.
 2. Depress brake pedal until vehicle stops.
 3. Release brake pedal for a few minutes to allow brake components to cool.
 4. Repeat steps 1 through 3 until pad and disc brake rotor are securely seated.

DISC BRAKE ROTOR

DISC BRAKE ROTOR : Inspection

INFOID:000000012227420

INSPECTION

Appearance

Check surface of disc brake rotor for uneven wear, cracks, or damage. Replace it if necessary. Refer to [BR-46, "DISC BRAKE ROTOR : Removal and Installation"](#).

RUNOUT

1. Check wheel bearing axial end play before inspection. Refer to [FAX-37, "Wheel Bearing"](#).
2. Secure disc brake rotor to wheel hub and bearing with wheel nuts at two wheel nut locations.
3. Measure runout using a dial gauge 10 mm (0.39 in) from disc brake rotor edge.

Runout (with it attached to the vehicle) : Refer to [BR-55, "Rear Disc Brake"](#)

4. Find installation position with a minimum runout by shifting disc brake rotor-to-wheel hub and bearing installation position by one hole at a time if runout exceeds limit value.
5. Refinish disc brake rotor if runout is outside limit even after performing above operation. When refinishing, use Tool.

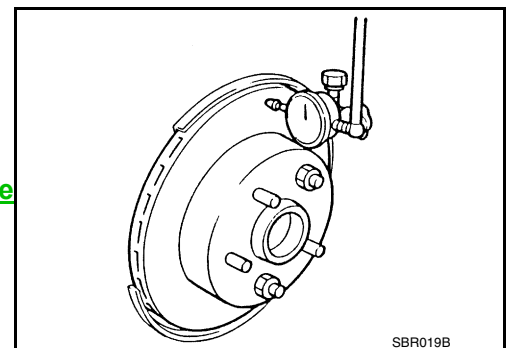

REAR DISC BRAKE

< PERIODIC MAINTENANCE >

Tool number : 38-PFM92 (—)

CAUTION:

- Check in advance that the thickness of the disc brake rotor is wear thickness + 0.3 mm (0.012 in) or more.
- If the thickness is less than wear thickness + 0.3 mm (0.012 in), replace the disc brake rotor.

Wear thickness : Refer to [BR-55, "Rear Disc Brake"](#).

THICKNESS

Check thickness of disc brake rotor using a micrometer. Replace disc brake rotor if thickness is below wear limit.

Wear thickness : Refer to [BR-55, "Rear Disc Brake"](#).

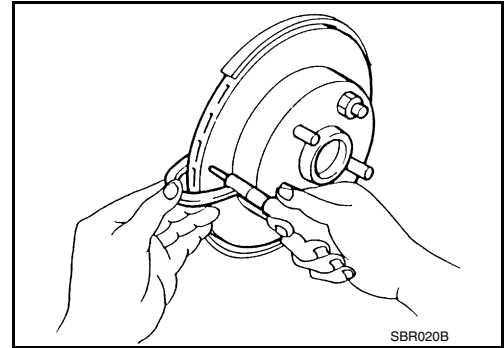

DISC BRAKE ROTOR : Brake Burnishing

INFOID:000000012227421

CAUTION:

- Burnish contact surfaces between brake pads and disc brake rotor according to the following procedure after refinishing the disc brake rotor, replacing brake pads or if a soft pedal occurs at very low mileage.
 - Be careful of vehicle speed. Brakes do not operate firmly/securely until pads and disc brake rotor are securely seated.
 - Only perform this procedure under safe road and traffic conditions. Use extreme caution.
1. Drive vehicle on straight, flat road.
 2. Depress brake pedal until vehicle stops.
 3. Release brake pedal for a few minutes to allow brake components to cool.
 4. Repeat steps 1 through 3 until pad and disc brake rotor are securely seated.

BRAKE PEDAL

< REMOVAL AND INSTALLATION >

REMOVAL AND INSTALLATION

BRAKE PEDAL

Exploded View

INFOID:000000011933958

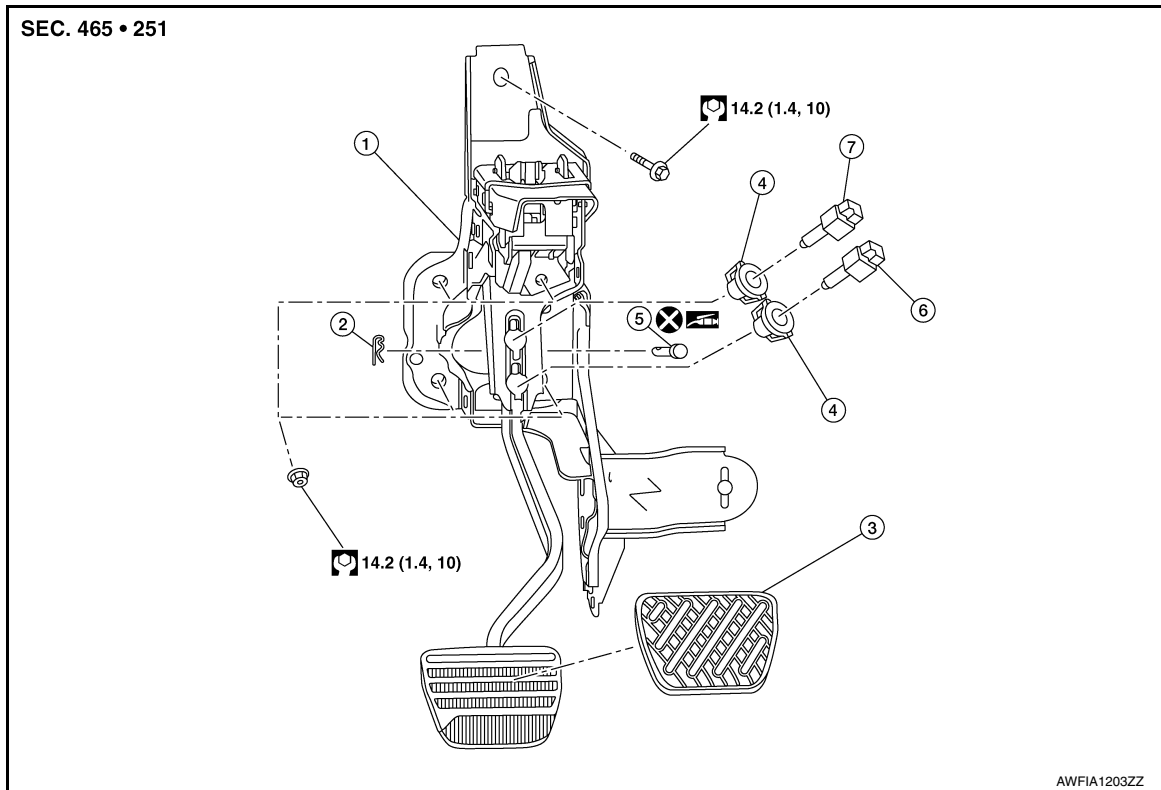

- | | | |
|--------------------------------|---------------|---------------------|
| 1. Brake pedal | 2. Snap pin | 3. Brake pedal pad |
| 4. Clip | 5. Clevis pin | 6. Stop lamp switch |
| 7. Brake pedal position switch | | |

Removal and Installation

INFOID:000000011933959

REMOVAL

1. Remove instrument lower panel LH. Refer to [IP-23, "Removal and Installation"](#).
2. Remove lower knee protector. Refer to [IP-14, "Exploded View"](#).
3. Remove accelerator pedal. Refer to [ACC-3, "Removal and Installation"](#).
4. Disconnect harness connectors from stop lamp switch and brake pedal position switch.
5. Remove stop lamp switch and brake pedal position switch from brake pedal.
6. Remove snap pin (1) and clevis pin (2) from brake pedal.

CAUTION:

Do not reuse the clevis pin.

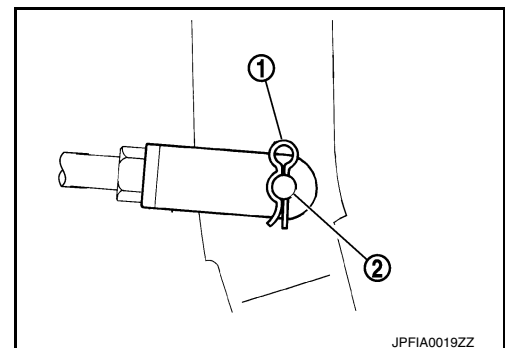

BRAKE PEDAL

< REMOVAL AND INSTALLATION >

7. Disconnect brake booster clevis from brake pedal.
8. Disconnect steering column assembly pinch bolt and position steering column assembly aside to gain access to brake pedal. Refer to [ST-32. "Exploded View"](#).
9. Remove brake pedal assembly nuts.
NOTE:
Remove top brake pedal assembly nut first.
10. Remove harness clips from brake pedal.
11. Remove brake pedal.

INSPECTION AFTER REMOVAL

- Check the following items and replace the brake pedal if necessary.
 - Check brake pedal upper rivet (B) for deformation.
 - Check brake pedal for bend, damage, and cracks on welded parts.
 - Check overlap distance (X) between sub-bracket (A) and slide plate (C).

**Overlap distance (X) : Refer to [BR-53. "Brake Pedal"](#).
between sub-bracket
(A) and slide plate (C)**

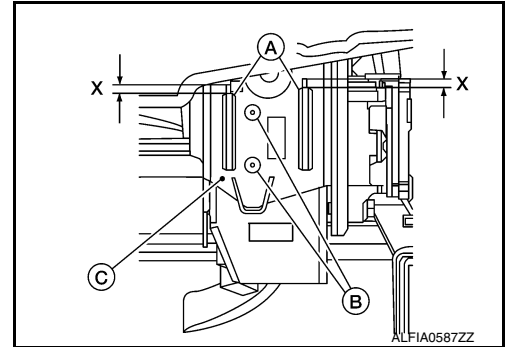

INSTALLATION

Installation is in the reverse order of removal.

CAUTION:

Do not reuse the clevis pin.

- Adjust the brake pedal height after installing the brake pedal. Refer to [BR-53. "Brake Pedal"](#).
- Tighten the clevis lock nut to the specified torque. Refer to [BR-20. "Exploded View"](#).

BRAKE PIPING

< REMOVAL AND INSTALLATION >

BRAKE PIPING

FRONT

FRONT : Exploded View

INFOID:000000012227476

WITHOUT ICC

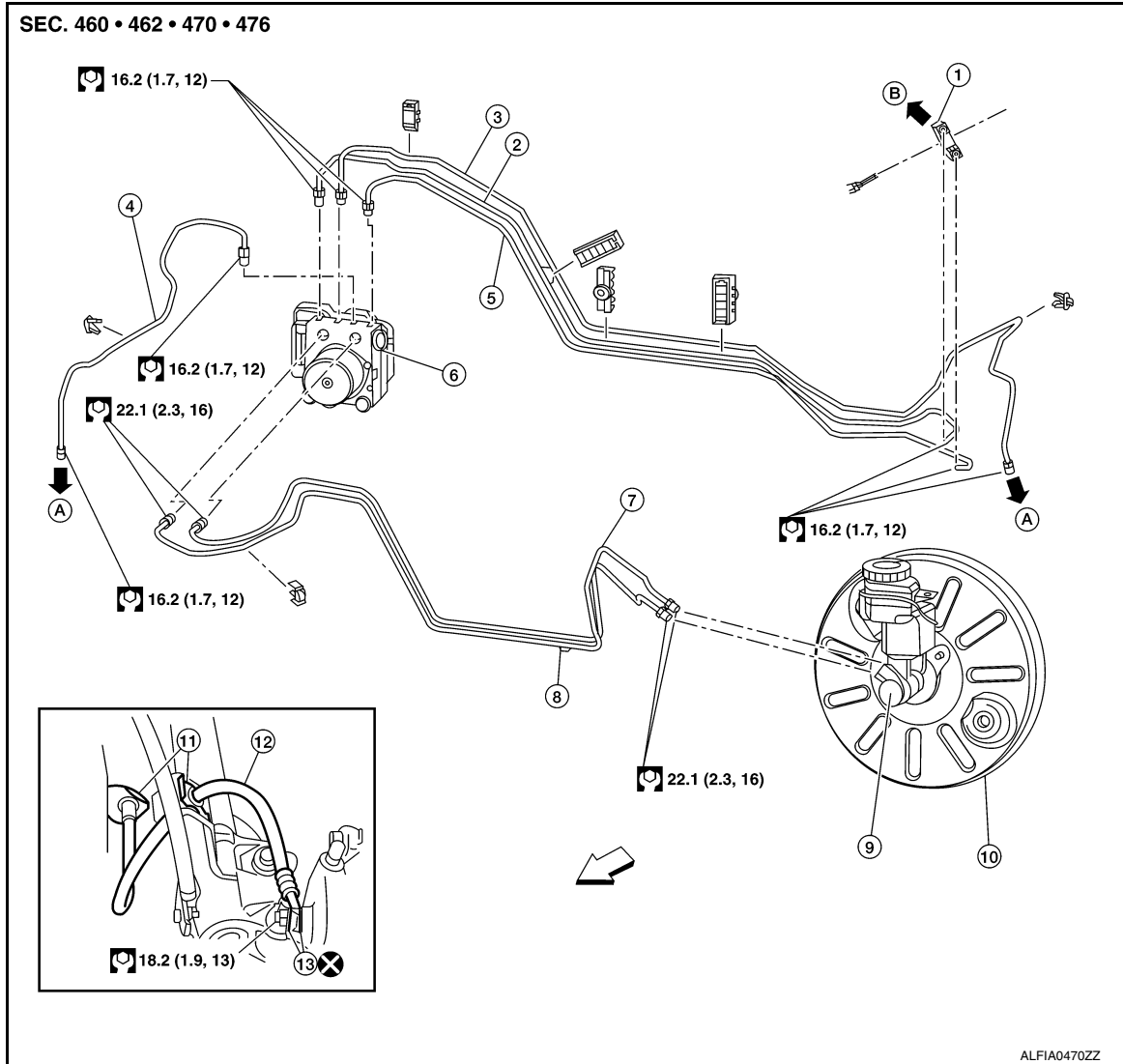

- | | | |
|---|---|--|
| 1. Brake pipe connector | 2. ABS actuator to connector brake pipe tube (RH) | 3. Brake tube (LH) |
| 4. Brake tube (RH) | 5. ABS actuator to connector brake pipe tube (LH) | 6. ABS actuator and electric unit (control unit) |
| 7. Master cylinder primary to ABS actuator brake tube | 8. Master cylinder secondary to ABS actuator brake tube | 9. Master cylinder |
| 10. Brake booster | 11. Lock plate | 12. Front brake hose |
| 13. Copper sealing washers | A. To front brake hose | B. To rear brake pipe |

⇐ Front

BRAKE PIPING

< REMOVAL AND INSTALLATION >

WITH ICC

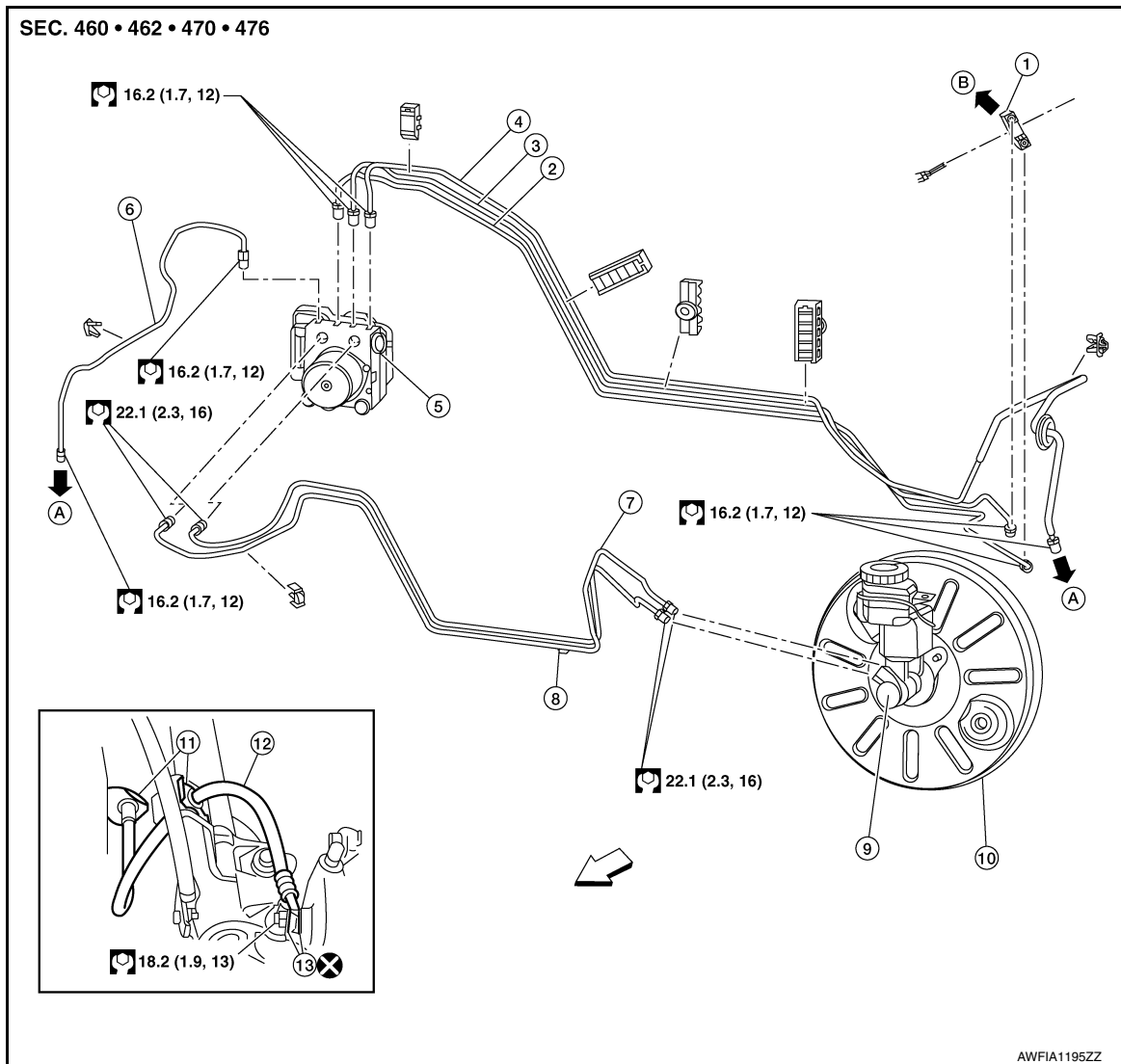

- | | | |
|---|---|--|
| 1. Brake pipe connector | 2. ABS actuator to connector brake tube (LH) | 3. ABS actuator to connector brake tube (RH) |
| 4. Brake tube (LH) | 5. ABS actuator and electric unit (control unit) | 6. Brake tube (RH) |
| 7. Master cylinder secondary to ABS actuator brake tube | 8. Master cylinder primary to ABS actuator brake tube | 9. Master cylinder |
| 10. Brake booster | 11. Lock plate | 12. Front brake hose |
| 13. Copper sealing washers | A. To front brake hose | B. To rear brake pipe |

⇐ Front

A
B
C
D
E
BR
G
H
I
J
K
L
M
N
O
P

BRAKE PIPING

< REMOVAL AND INSTALLATION >

FRONT : Hydraulic Piping

INFOID:000000012227477

WITHOUT ICC

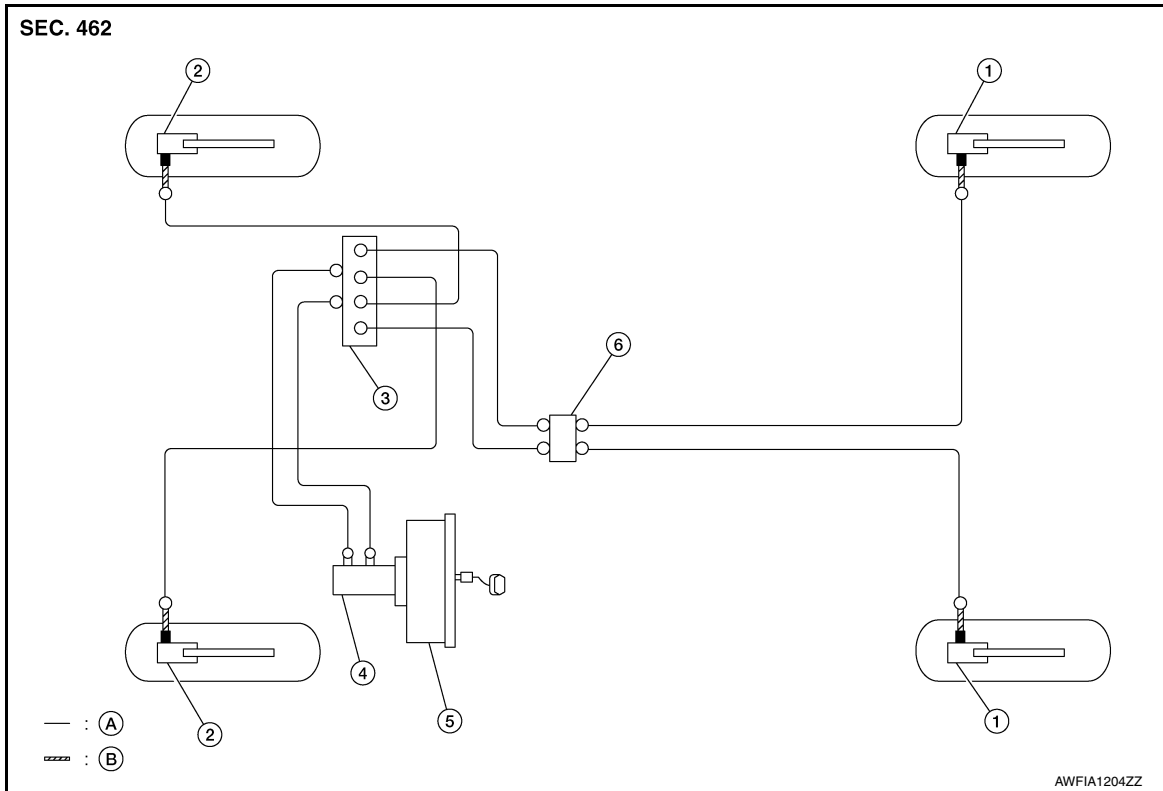

- | | | |
|--------------------|---------------------|--|
| 1. Rear disc brake | 2. Front disc brake | 3. ABS actuator and electric unit (control unit) |
| 4. Master cylinder | 5. Booster | 6. Connector |
| A. Brake tube | B. Brake hose | |
- Flare nut
 ■ Union bolt

BRAKE PIPING

< REMOVAL AND INSTALLATION >

WITH ICC

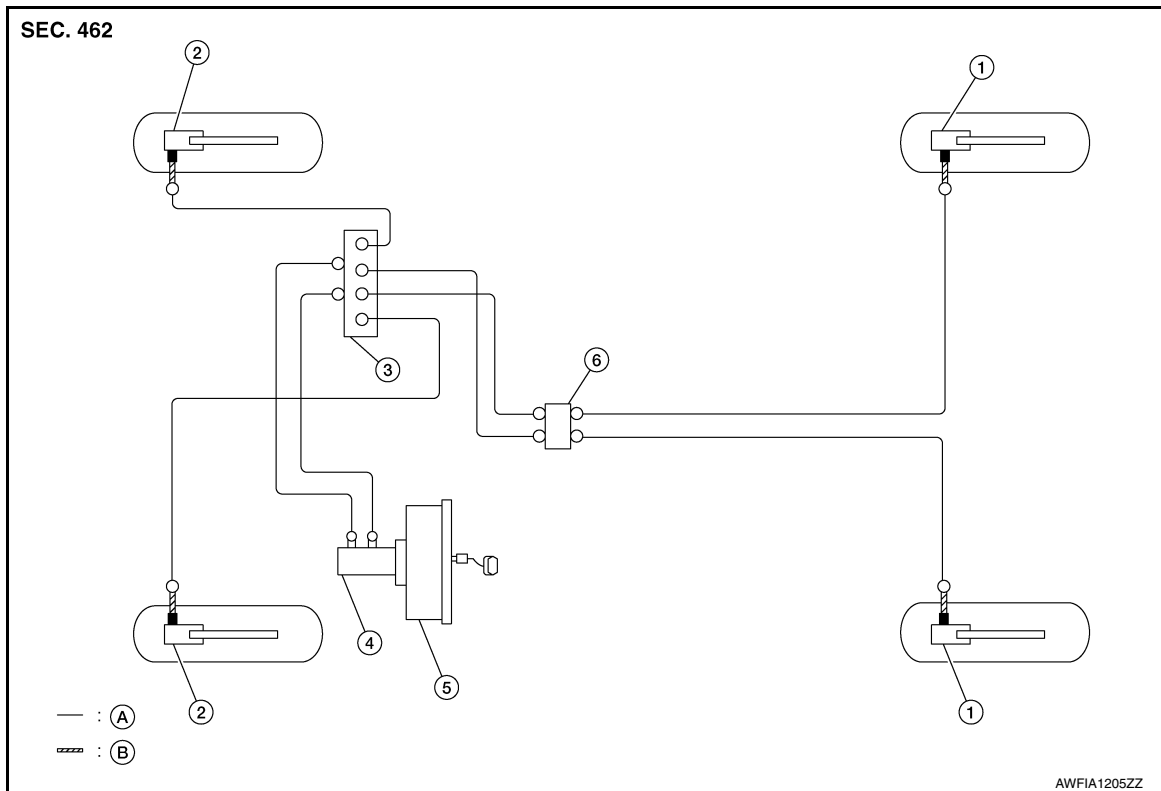

- | | | |
|--------------------|---------------------|--|
| 1. Rear disc brake | 2. Front disc brake | 3. ABS actuator and electric unit (control unit) |
| 4. Master cylinder | 5. Booster | 6. Connector |
| A. Brake tube | B. Brake hose | |

○ Flare nut

■ Union bolt

FRONT : Removal and Installation

INFOID:000000012227478

CAUTION:

- All hoses and piping (tubes) must be free from excessive bending, twisting and pulling.
- Make sure there is no interference with other parts when turning steering both clockwise and counterclockwise.
- Do not spill or splash brake fluid on painted surfaces. Brake fluid may seriously damage paint. Wipe it off immediately and wash with water if it gets on a painted surface.
- Do not allow foreign matter (e.g. dust) and oils other than brake fluid to enter the reservoir tank.

NOTE:

When removing components such as hoses, tubes/lines, etc., cap or plug openings to prevent fluid from spilling.

REMOVAL

1. Remove cap from reservoir tank.
2. Remove wheels and tires using a power tool. Refer to [WT-67. "Removal and Installation"](#).
3. Loosen flare nut with a flare nut wrench and separate brake tube from hose.
CAUTION:
 - Do not scratch flare nut and brake pipe.
 - All brake hoses and pipes must be free from excessive bending, twisting and pulling.
4. Remove lock plate and remove brake hose.
5. Remove union bolt and remove brake hose from caliper. Remove and discard copper sealing washers.
CAUTION:
Do not reuse the copper sealing washers.
6. Remove brake hose.

BRAKE PIPING

< REMOVAL AND INSTALLATION >

INSTALLATION

CAUTION:

Do not allow foreign matter (e.g. dust) and oils other than brake fluid to enter the reservoir tank.

1. Assemble union bolt and new copper sealing washers on brake hose.

CAUTION:

Do not reuse the copper sealing washers.

2. Install brake hose to brake tube. Temporarily tighten flare nut by hand until it does not rotate further. Secure brake hose to bracket with lock plate.

CAUTION:

Check that the brake hoses and pipes are not bent or twisted.

3. Tighten flare nut to specified torque using a flare nut crowfoot and torque wrench. Refer to [BR-22, "FRONT : Exploded View"](#).

CAUTION:

Do not scratch flare nut or brake tube.

4. Refill brake fluid and perform air bleeding procedure. Refer to [BR-15, "Bleeding Brake System"](#).
5. Install wheels and tires using a power tool. Refer to [WT-67, "Removal and Installation"](#).
6. Perform inspection after installation. Refer to [BR-14, "Inspection"](#).

REAR

REAR : Exploded View

INFOID:000000012227479

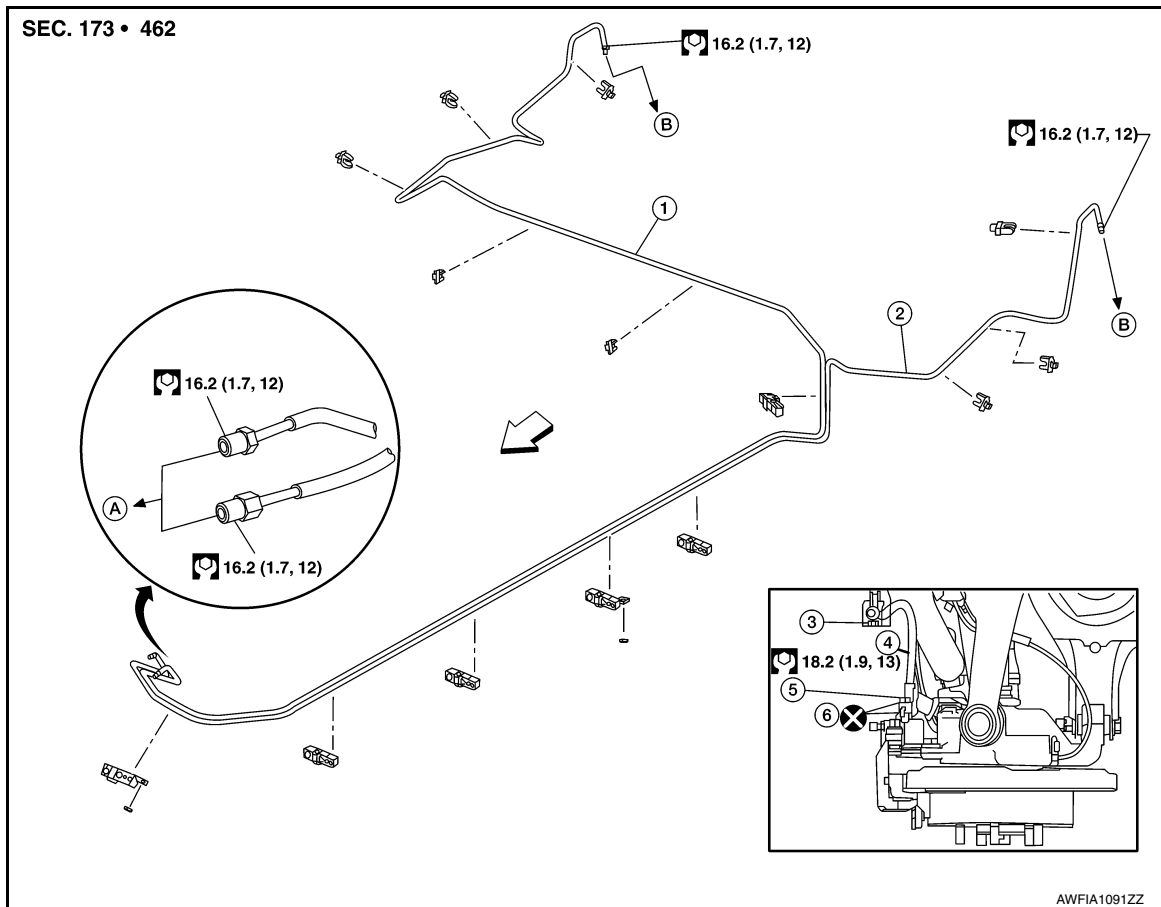

1. Rear brake pipe (RH)
4. Rear brake hose
- A. To brake pipe connector

2. Rear brake pipe (LH)
5. Union bolt
- B. To rear brake hose

3. Lock plate
6. Copper sealing washers
- ← Front

BRAKE PIPING

< REMOVAL AND INSTALLATION >

REAR : Hydraulic Piping

INFOID:000000012227480

WITHOUT ICC

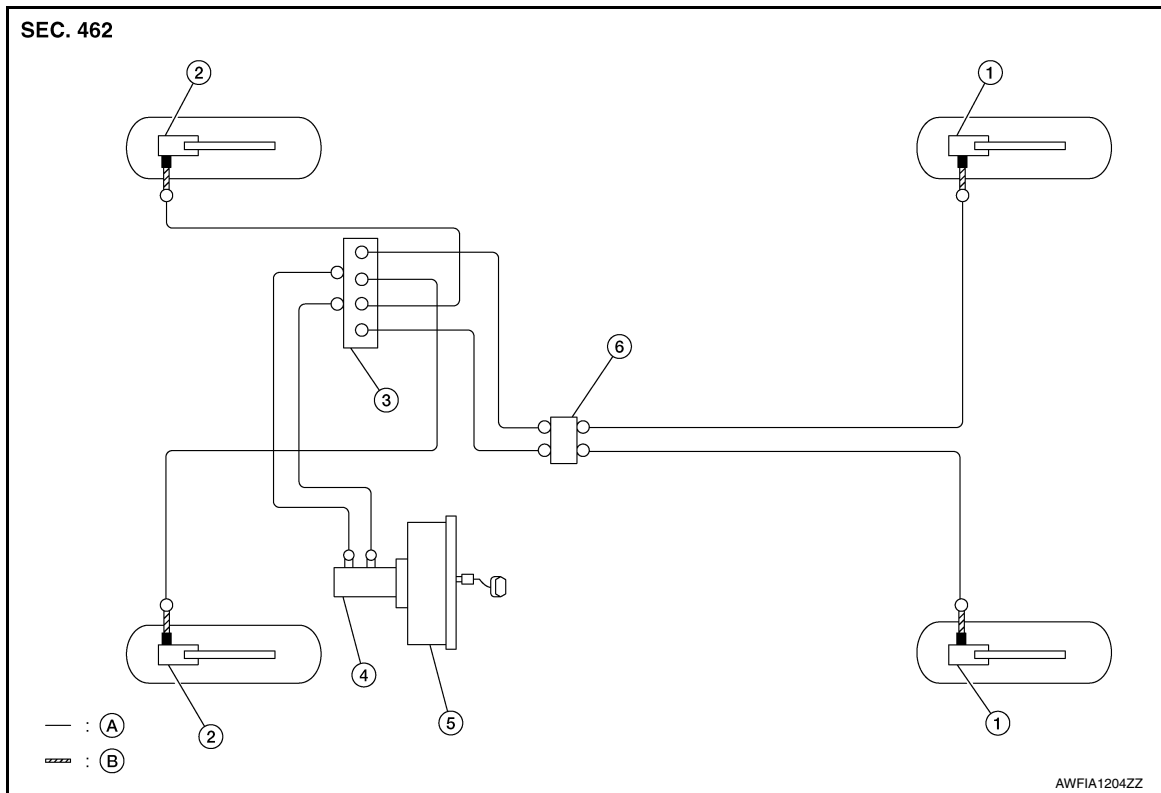

- | | | |
|--------------------|---------------------|--|
| 1. Rear disc brake | 2. Front disc brake | 3. ABS actuator and electric unit (control unit) |
| 4. Master cylinder | 5. Booster | 6. Connector |
| A. Brake tube | B. Brake hose | |
- Flare nut
 ■ Union bolt

A
B
C
D
E
BR
G
H
I
J
K
L
M
N
O
P

BRAKE PIPING

< REMOVAL AND INSTALLATION >

WITH ICC

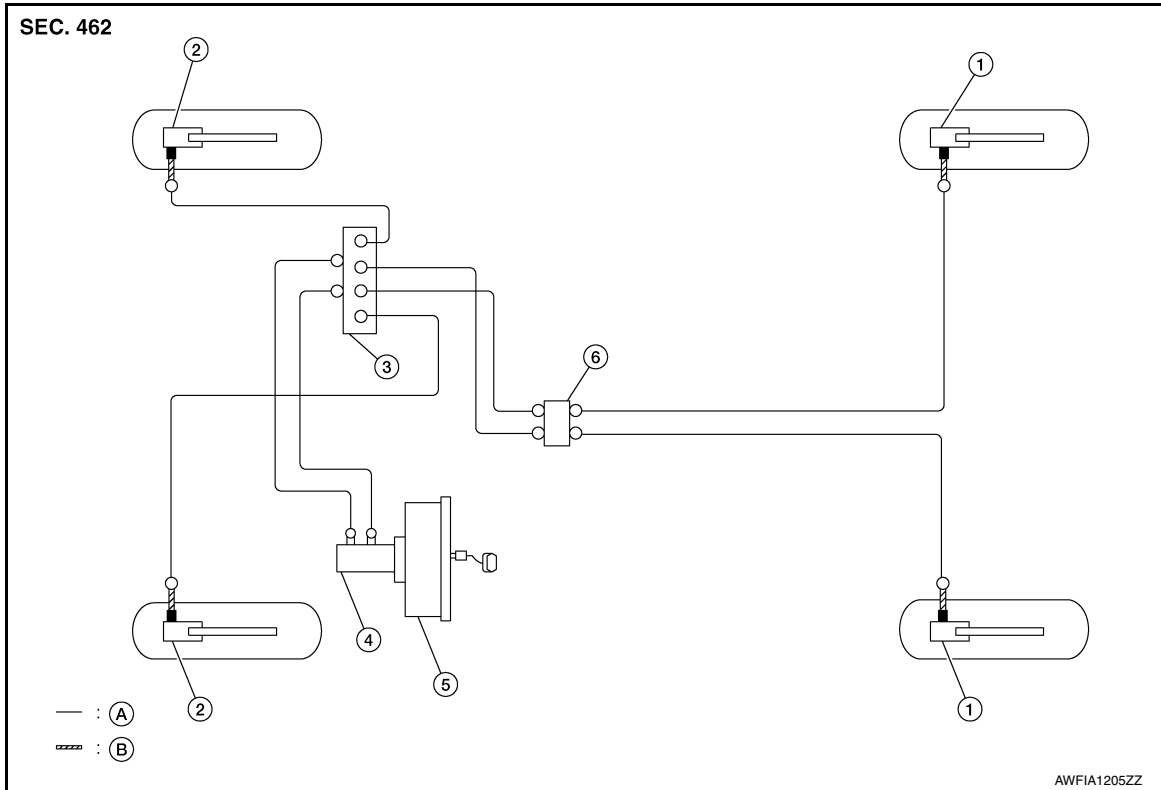

- | | | |
|--------------------|---------------------|--|
| 1. Rear disc brake | 2. Front disc brake | 3. ABS actuator and electric unit (control unit) |
| 4. Master cylinder | 5. Booster | 6. Connector |
| A. Brake tube | B. Brake hose | |

○ Flare nut

■ Union bolt

REAR : Removal and Installation

INFOID:000000012227481

CAUTION:

- All hoses and piping (tubes) must be free from excessive bending, twisting and pulling.
- The brake piping is an important safety part. If a brake fluid leak is detected, always disassemble the parts. Replace applicable part with a new one, if necessary.
- Do not spill or splash brake fluid on painted surfaces. Brake fluid may seriously damage paint. Wipe it off immediately and wash with water if it gets on a painted surface.
- Do not allow foreign matter (e.g. dust) and oils other than brake fluid to enter the reservoir tank.

NOTE:

When removing components such as hoses, tubes/lines, etc., cap or plug openings to prevent fluid from spilling.

REMOVAL

1. Remove cap from reservoir tank.
2. Remove wheels and tires using a power tool. Refer to [WT-67. "Removal and Installation"](#).
3. Loosen flare nut with a flare nut wrench and separate brake tube from hose.

CAUTION:

- Do not scratch flare nut and brake pipe.
 - All brake hoses and pipes must be free from excessive bending, twisting and pulling.
4. Remove lock plate and remove brake hose.

BRAKE PIPING

< REMOVAL AND INSTALLATION >

5. Remove union bolt (A) and brake hose from brake caliper. Remove and discard copper sealing washers.

CAUTION:

Do not reuse copper sealing washers.

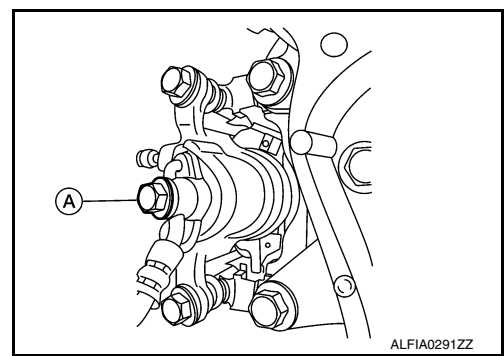

INSTALLATION

CAUTION:

Do not allow foreign matter (e.g. dust) and oils other than brake fluid to enter the reservoir tank.

1. Assemble union bolt (A) and the copper sealing washers (1) to brake hose and install it as an assembly to brake caliper. Align brake hose L-pin by aligning it with brake caliper hole, and tighten union bolt (A) to specified torque.

CAUTION:

Do not reuse copper sealing washers.

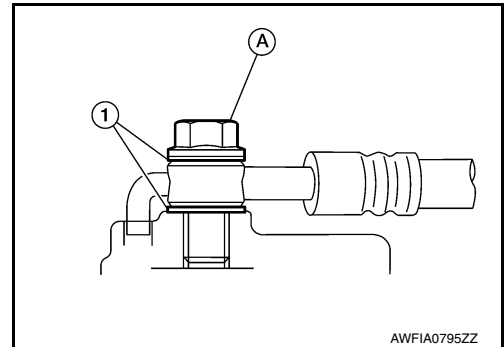

2. Install brake hose to brake tube. Temporarily tighten flare nut by hand until it does not rotate further. Secure brake hose to bracket with lock plate.

CAUTION:

Check that brake hoses and pipes are not bent or twisted.

3. Tighten flare nut to the specified torque using a flare nut crowfoot and torque wrench. Refer to [BR-26, "REAR : Exploded View"](#).

CAUTION:

Do not scratch flare nut or brake tube.

4. Refill brake fluid and perform the air bleeding procedure. Refer to [BR-15, "Bleeding Brake System"](#).

CAUTION:

Do not reuse drained brake fluid.

5. Install wheels and tires using a power tool. Refer to [WT-67, "Removal and Installation"](#).
6. Perform inspection after installation. Refer to [BR-14, "Inspection"](#).

BRAKE MASTER CYLINDER

< REMOVAL AND INSTALLATION >

BRAKE MASTER CYLINDER

Exploded View

INFOID:000000011933964

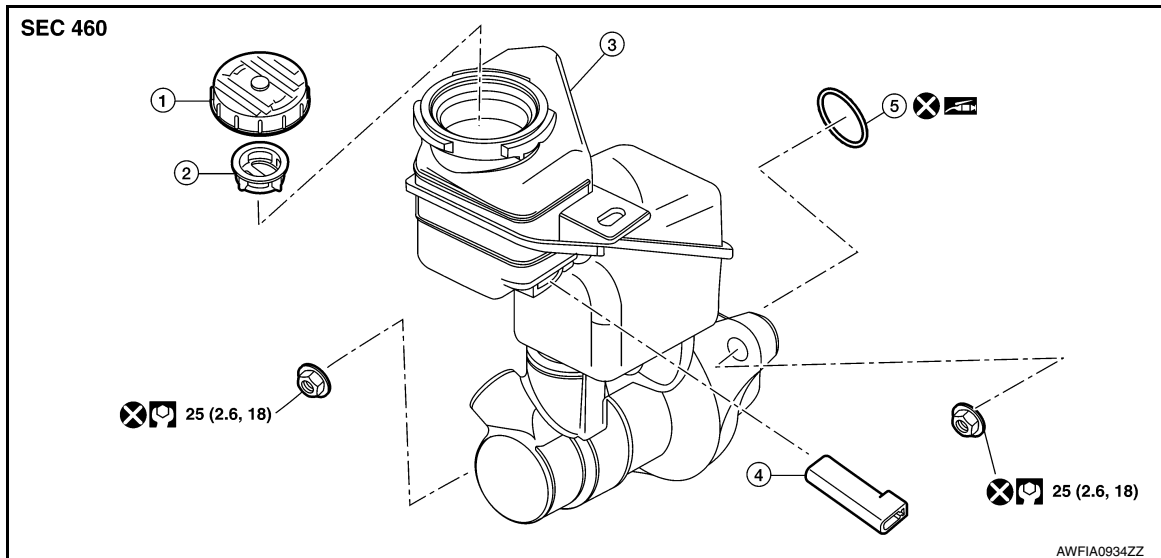

- | | | |
|-----------------------------|-----------------|--------------------|
| 1. Reservoir cap | 2. Oil strainer | 3. Master cylinder |
| 4. Brake fluid level switch | 5. O-ring | |

 PBC (Poly Betel Cuprysil) grease or silicone-based grease

Removal and Installation

INFOID:000000011933965

CAUTION:

- Do not spill or splash brake fluid on painted areas; it may cause paint damage. If brake fluid is splashed on painted areas, wash it away with water immediately.
- Do not reuse drained brake fluid.

NOTE:

When removing components such as hoses, tubes/lines, etc., cap or plug openings to prevent fluid from spilling.

REMOVAL

1. Drain brake fluid. Refer to [BR-14, "Drain and Refill"](#).
2. Remove air cleaner assembly and air ducts. Refer to [EM-26, "Removal and Installation"](#).
3. Disconnect harness connector from brake fluid level switch.
4. Remove brake fluid level switch.
5. Separate brake pipes from master cylinder using a flare nut wrench.

CAUTION:

Do not scratch the flare nut or the brake pipe.

6. Remove master cylinder nuts.
7. Remove master cylinder.
8. Remove and discard O-ring from the master cylinder.

CAUTION:

Do not depress the brake pedal after the master cylinder assembly is removed.

Do not reuse O-ring.

INSTALLATION

CAUTION:

Do not spill or splash brake fluid on painted areas; it may cause paint damage. If brake fluid is splashed on painted areas, wash it away with water immediately.

Installation is in the reverse order of removal.

BRAKE MASTER CYLINDER

< REMOVAL AND INSTALLATION >

- Apply PBC (Poly Butyl Cuprysil) grease or silicone-based grease to brake booster at position (A) as shown. Be sure the O-ring is in the proper position before installing the master cylinder to the brake booster.

CAUTION:

Do not reuse O-ring.

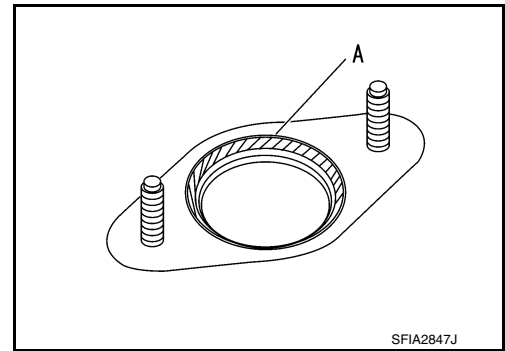

- Tighten brake tube flare nut to the specified torque using a flare nut crowfoot and torque wrench. Refer to [BR-22. "FRONT : Exploded View"](#).

CAUTION:

Do not scratch the flare nut or the brake pipe.

- After installation, perform air bleeding for brakes. Refer to [BR-15. "Bleeding Brake System"](#).

A
B
C
D
E
BR
G
H
I
J
K
L
M
N
O
P

BRAKE BOOSTER

< REMOVAL AND INSTALLATION >

BRAKE BOOSTER

Exploded View

INFOID:000000011933966

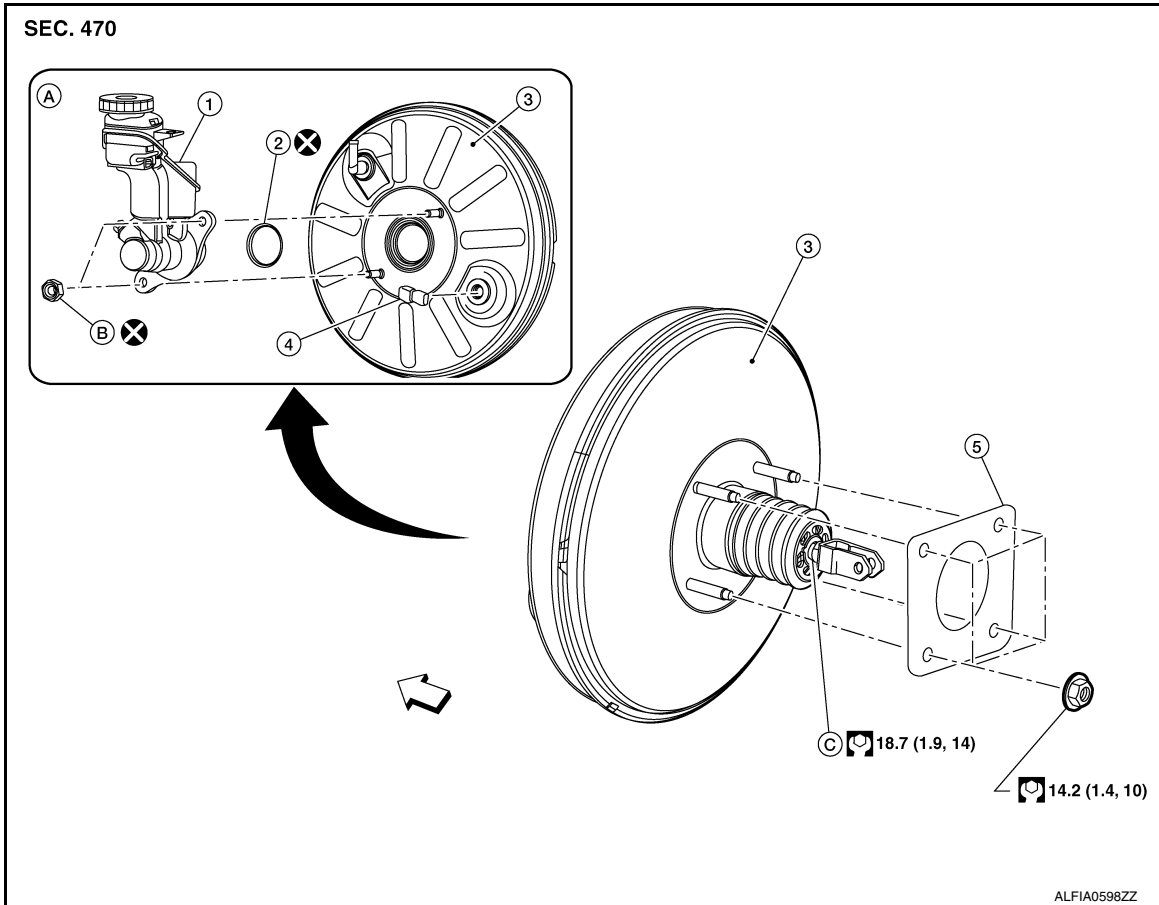

- | | | |
|----------------------------------|--------------------|--|
| 1. Master cylinder | 2. O-ring | 3. Brake booster |
| 4. Brake booster pressure sensor | 5. Gasket | A. Refer to BR-30, "Removal and Installation." |
| B. Master cylinder nut | C. Clevis lock nut | |

Removal and installation

INFOID:000000011933967

REMOVAL

1. Release fuel pressure from fuel system. Refer to [EC-168, "Work Procedure."](#)
2. Remove instrument lower panel LH. Refer to [IP-23, "Removal and Installation."](#)
3. Remove lower knee protector. Refer to [IP-14, "Exploded View."](#)
4. Loosen clevis lock nut (A) and remove clevis bracket (B) from input rod (C).

← :Front

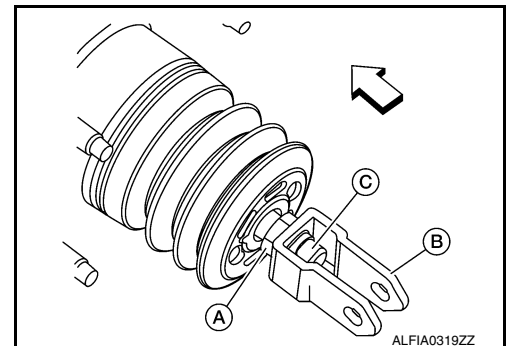

5. Disconnect steering column assembly pinch bolt and position steering column assembly aside. Refer to [ST-32, "Exploded View."](#)

BRAKE BOOSTER

< REMOVAL AND INSTALLATION >

6. Remove vacuum hose. Refer to [BR-34, "Exploded View"](#).
7. Remove brake master cylinder. Refer to [BR-30, "Removal and Installation"](#).
8. Disconnect harness connector from brake booster pressure sensor.
9. Remove brake booster pressure sensor.
10. Disconnect throttle actuator electrical connector.
11. Disconnect fuel line main connections. Refer to [FL-4, "Quick Connector"](#).
12. Disconnect harness connector from Intelligent Key® warning buzzer and remove Intelligent Key® warning buzzer from LH strut tower. Refer to [DLK-201, "Removal and Installation"](#).
13. Remove cowl top and cowl top extension. Refer to [EXT-25, "Removal and Installation"](#).
14. Remove strut tower bar. Refer to [EXT-25, "Removal and Installation"](#).
15. Apply protective tape to shaded area (A).

← :Front

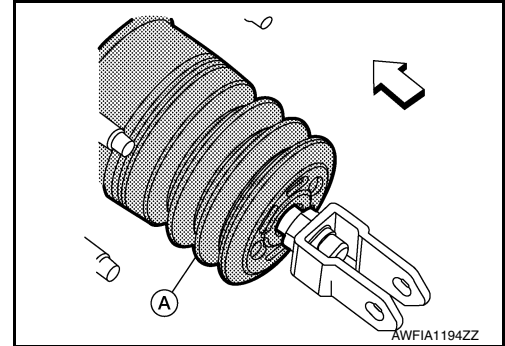

16. Remove brake booster.
17. Remove and discard brake booster gasket.

CAUTION:

Do not reuse brake booster gasket.

INSTALLATION

Installation is in the reverse order of removal.

- Prior to installation, loosen clevis lock nut (1) and adjust input rod (2) to specified length (B).

Length (B) : Refer to [BR-54, "Brake Booster"](#).

- After input rod adjustment, temporarily tighten clevis lock nut for installation of brake booster.

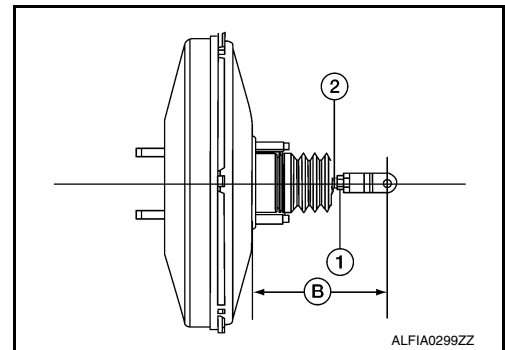

VACUUM LINES

< REMOVAL AND INSTALLATION >

VACUUM LINES

Exploded View

INFOID:000000011933968

Vacuum hose without check valve

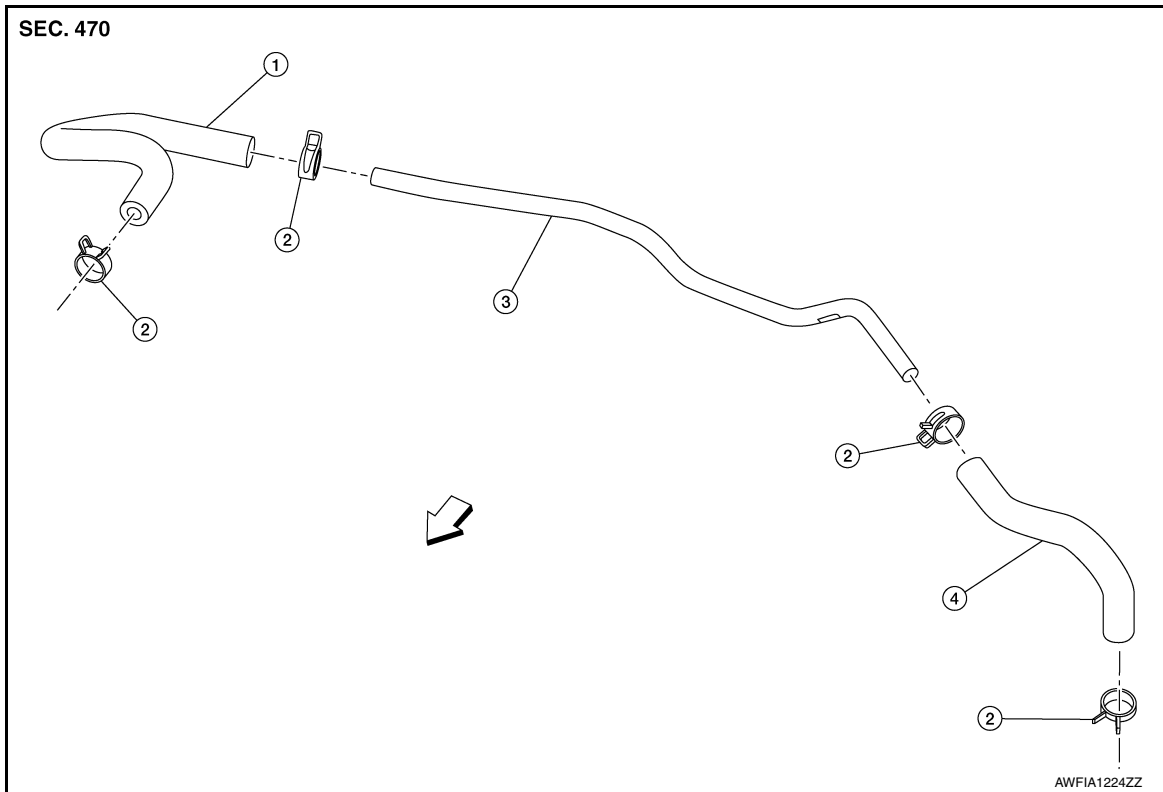

- 1. Vacuum hose
- 4. Vacuum hose

- 2. Clamp
- ← Front

- 3. Vacuum piping

VACUUM LINES

< REMOVAL AND INSTALLATION >

Vacuum hose with check valve

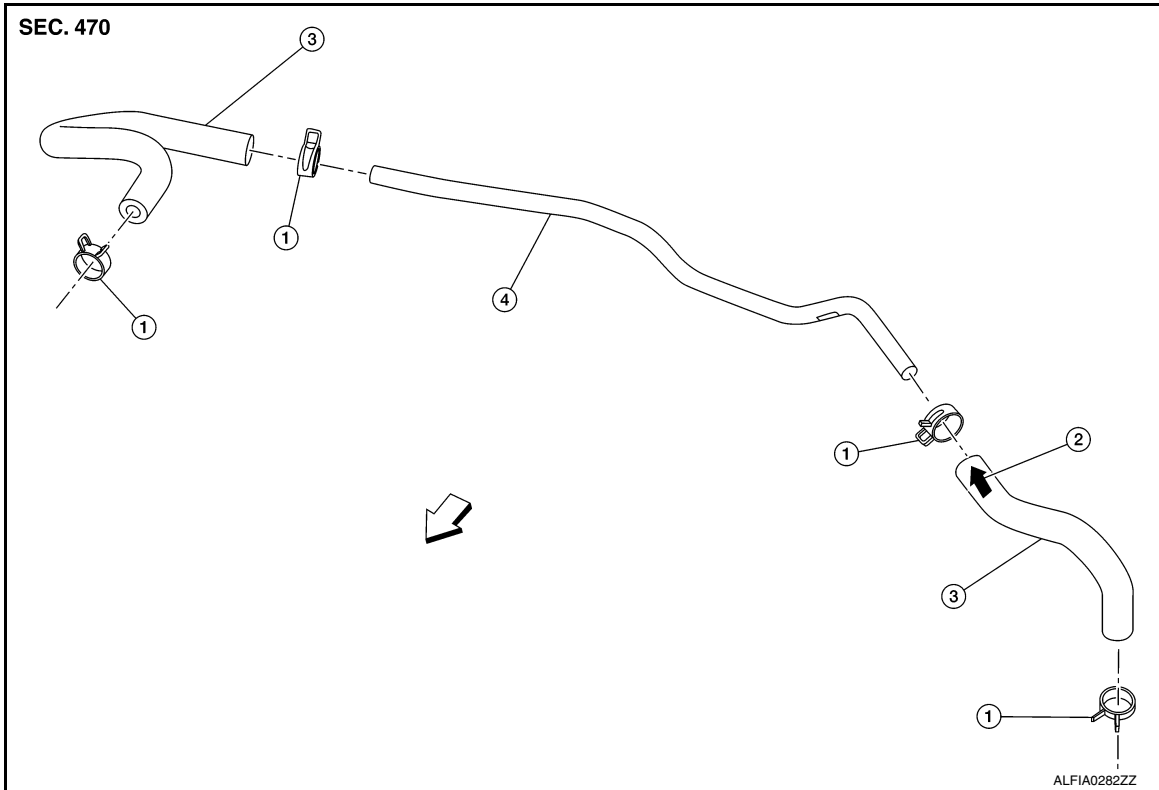

1. Clamp
 2. Check valve direction stamp
 3. Vacuum hose
 4. Vacuum piping
- ↩ Front

Removal and Installation

INFOID:0000000011933969

REMOVAL

1. Disconnect vacuum hose from brake booster.
2. Disconnect vacuum hose from engine intake manifold.
3. Remove air cleaner case and air duct. Refer to [EM-26, "Removal and Installation"](#).
4. Release clips and remove vacuum pipe with vacuum hoses attached.
5. Remove vacuum hoses from vacuum pipe.

INSPECTION AFTER REMOVAL

Visual Inspection

Check for correct installation, damage and deterioration of vacuum hoses and pipe.

Air-tightness Check

- Connect a suitable tool to inspect check valve operation. Refer to [BR-9, "Inspection - Vacuum Hose Without Check Valve"](#) (Vacuum Hose Without Check Valve) or [BR-9, "Inspection - Vacuum Hose With Check Valve"](#) (Vacuum Hose With Check Valve).
- Replace vacuum hose component or check valve if out of specification.

INSTALLATION

Installation is in the reverse order of removal.

CAUTION:

VACUUM LINES

< REMOVAL AND INSTALLATION >

- Because vacuum hose contains a check valve, vacuum hose must be installed in correct position for proper operation. Refer to stamp on end of vacuum hose to confirm correct installation. The brake booster will not operate normally if vacuum hose with check valve is installed in wrong direction.
- Insert vacuum pipe into vacuum hose at least 24 mm (0.94 in) as shown.
- Do not use lubricating oil during installation.

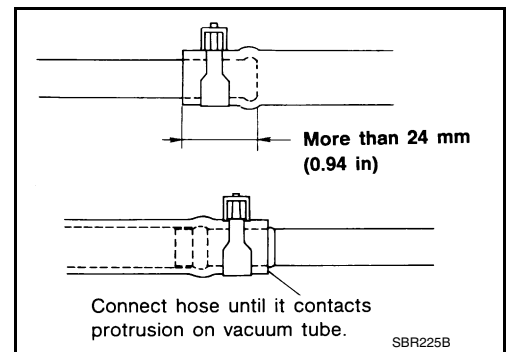

FRONT DISC BRAKE

< REMOVAL AND INSTALLATION >

FRONT DISC BRAKE

BRAKE PAD

BRAKE PAD : Exploded View

INFOID:0000000011933970

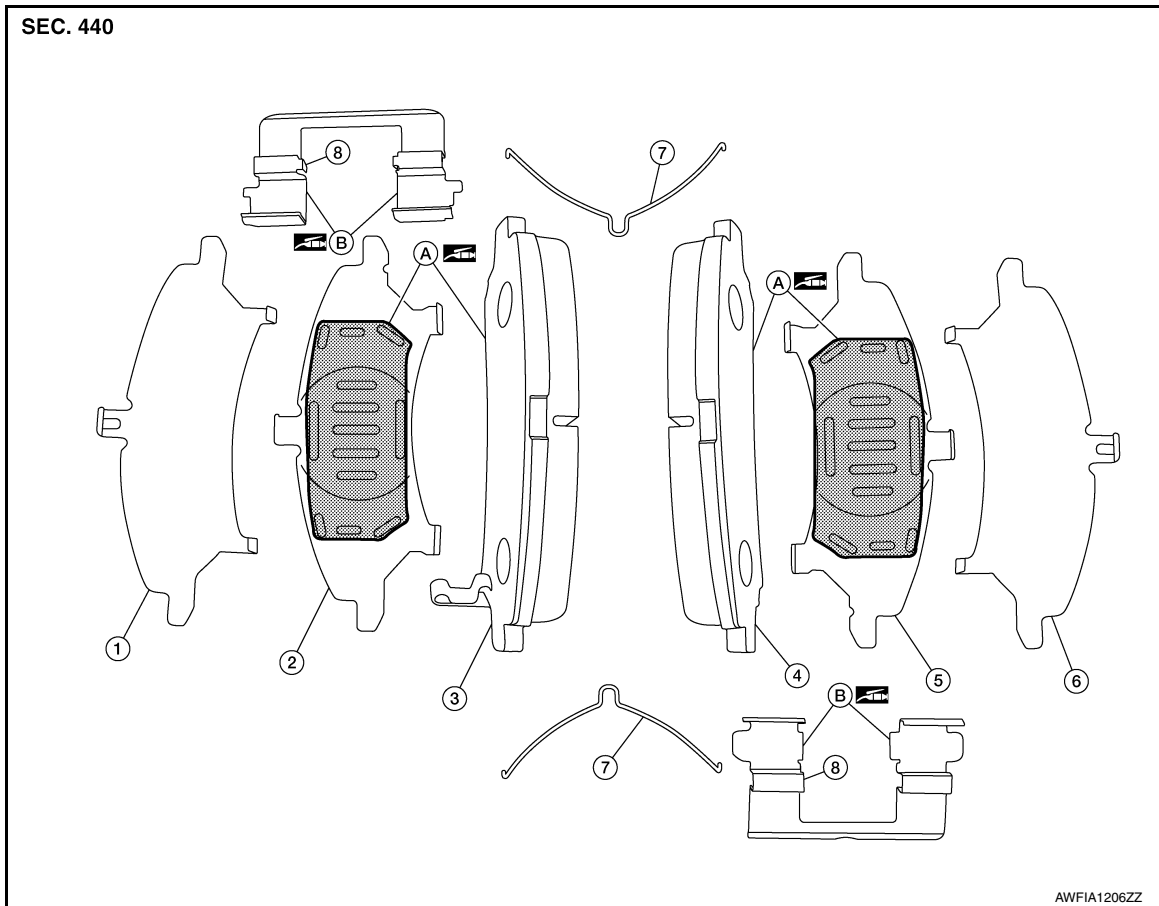

- | | | |
|-------------------------|------------------|----------------------------|
| 1. Inner shim cover | 2. Inner shim | 3. Inner pad |
| 4. Outer pad | 5. Outer shim | 6. Outer shim cover |
| 7. Anti-rattle clips | 8. Pad retainers | A. Molykote AS-880N grease |
| B. Molykote 7439 grease | | |

BRAKE PAD : Removal and Installation

INFOID:0000000011933971

WARNING:

Clean dust on brake caliper and brake pad with a vacuum dust collector to minimize the hazards of airborne particles or other material.

CAUTION:

- Do not depress the brake pedal while removing the brake pads because the pistons may pop out.
- It is not necessary to remove bolts on torque member and brake hose except for disassembly or replacement of brake caliper. For brake pad removal, hang brake caliper with a wire so as not to stretch brake hose.
- If brake fluid or grease adheres to the brake caliper or disc brake rotor, quickly wipe it off.
- Do not reuse drained brake fluid.

REMOVAL

1. Observe brake fluid level in reservoir tank. Partially drain brake fluid if necessary. Refer to [BR-14, "Drain and Refill"](#).

CAUTION:

Do not reuse drained brake fluid.

FRONT DISC BRAKE

< REMOVAL AND INSTALLATION >

2. Remove front wheels and tires using a power tool. Refer to [WT-67. "Removal and Installation"](#).
3. Remove upper and lower slide pin bolts.
NOTE:
Note slide pin orientation during removal. The upper slide pin contains a bushing.
4. Remove brake caliper from torque member. Leaving brake hose attached, reposition brake caliper aside with wire.
5. Remove brake pads, shims, shim covers, pad retainers, and anti-rattle clips from torque member.
CAUTION:
 - Do not reuse the pad retainers and anti-rattle clips.
 - Do not damage the piston boot.
 - Do not drop the brake pads, shims, or the shim covers.
 - Note the position of components during removal to aid with installation.

INSTALLATION

1. Apply Molykote AS-880N grease between inner and outer shims and back of brake pads.
CAUTION:
When installing new brake pads, replace the shims and shim covers.
2. Install inner and outer shims and shim covers to inner pad and outer pad.
CAUTION:
Do not get grease on the inner and outer pad friction surfaces.
3. Apply Molykote 7439 grease (A) to pad retainer and attach pad retainer to torque member.

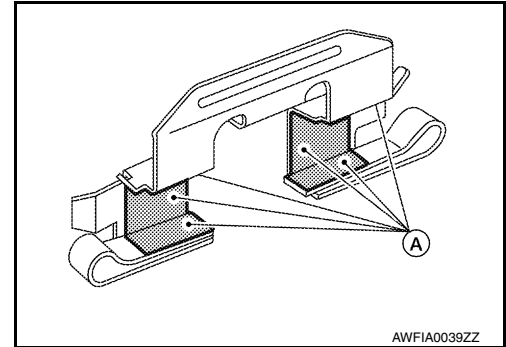

4. Install assembled inner and outer shims, shim covers, pads and anti-rattle clips to torque member.
CAUTION:
Do not get grease on the inner and outer pad or rotor friction surfaces.
5. Using a suitable tool, press pistons into brake caliper.
CAUTION:
Do not damage the piston boot.
6. Install brake caliper to torque member.
7. Install slide pin bolts and tighten to specification.
8. Install front wheels and tires. Refer to [WT-67. "Removal and Installation"](#).
9. Check brake fluid level and refill as necessary. Refer to [BR-14. "Inspection"](#).

INSPECTION AFTER INSTALLATION

1. Check drag of front disc brake. If any drag is found, follow the procedure described below.
2. Remove brake pads.
3. Using a suitable tool, press the pistons into brake caliper body.
CAUTION:
Do not damage the piston boots.
4. Install brake pads.
5. Depress brake pedal several times.
6. Check drag of front disc brake again. If any drag is found, disassemble brake caliper body.
7. Burnish contact surfaces after refinishing or replacing disc brake rotors or if a soft pedal occurs at very low mileage. Refer to [BR-16. "BRAKE PAD : Brake Burnishing"](#).

BRAKE CALIPER ASSEMBLY

FRONT DISC BRAKE

< REMOVAL AND INSTALLATION >

BRAKE CALIPER ASSEMBLY : Exploded View

INFOID:000000011933973

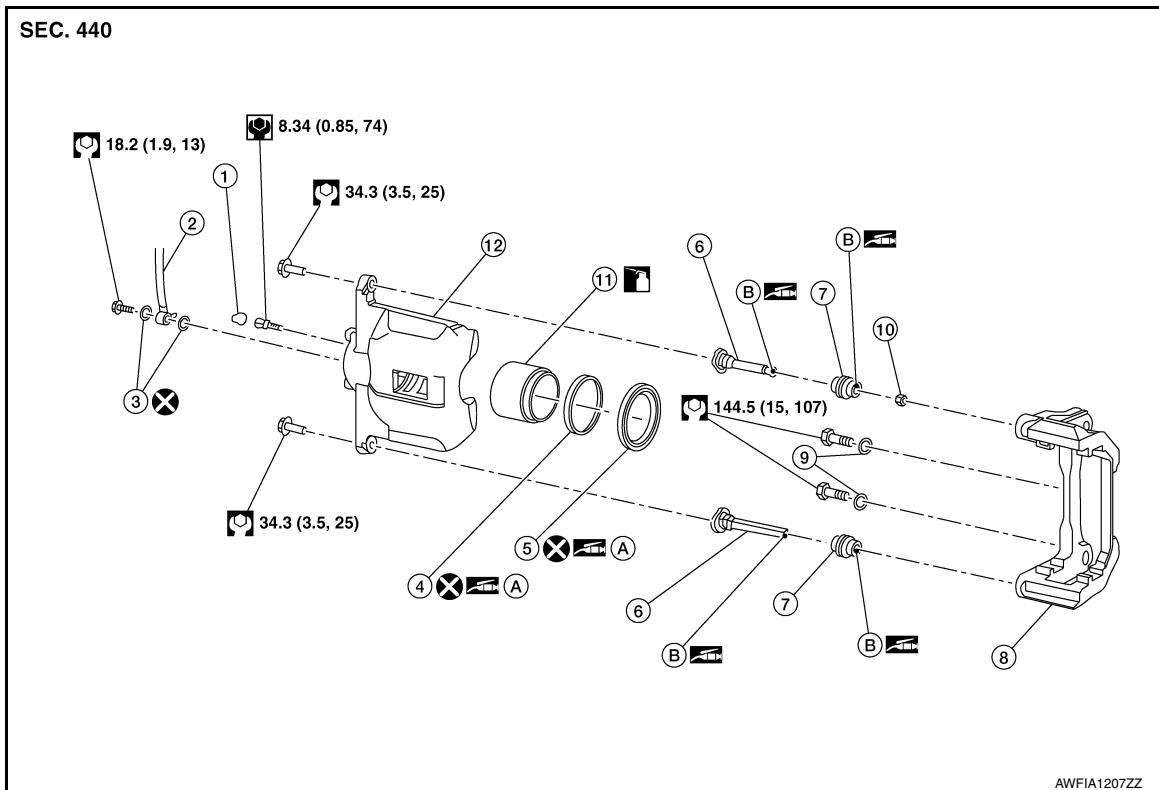

- | | | |
|-------------------|------------------|---------------------------|
| 1. Bleeder cap | 2. Brake hose | 3. Copper sealing washers |
| 4. Piston seal | 5. Piston boot | 6. Slide pin |
| 7. Slide pin boot | 8. Torque member | 9. Washer |
| 10. Bushing | 11. Piston | 12. Brake caliper body |
| A. Rubber grease | B. Niglube Rx-2 | |
-  Apply brake fluid.

BRAKE CALIPER ASSEMBLY : Removal and Installation

INFOID:000000011933974

WARNING:

Clean dust on brake caliper and brake pad with a vacuum dust collector to minimize the hazard of airborne particles or other materials.

CAUTION:

- Do not depress the brake pedal.
- Do not spill or splash brake fluid on painted areas; it may cause paint damage. If brake fluid is splashed on painted areas, wash it away with water immediately.
- Do not bend, twist or pull the brake hoses and piping.
- Do not reuse drained brake fluid.

NOTE:

When removing components such as hoses, tubes/lines, etc., cap or plug openings to prevent fluid from spilling.

REMOVAL

1. Remove reservoir cap from reservoir tank.
2. Remove front wheels and tires using a power tool. Refer to [WT-67, "Removal and Installation"](#).
3. Remove union bolt and then remove brake hose from brake caliper assembly. Discard copper sealing washers.

CAUTION:

Do not reuse copper sealing washers.

FRONT DISC BRAKE

< REMOVAL AND INSTALLATION >

4. Remove upper and lower slide pin bolts.

NOTE:

Note slide pin orientation during removal. The upper slide pin contains a bushing.

5. Remove brake caliper from the torque member.
6. Remove brake pads and shims from torque member.

INSTALLATION

Installation is in the reverse order of removal.

- Install union bolt (1) with new copper sealing washers (2) to brake hose. Align brake hose pin (A) with brake caliper protrusion (B). Tighten union bolt to specified torque. Refer to [BR-39, "BRAKE CALIPER ASSEMBLY : Exploded View"](#).

CAUTION:

Do not reuse copper sealing washers.

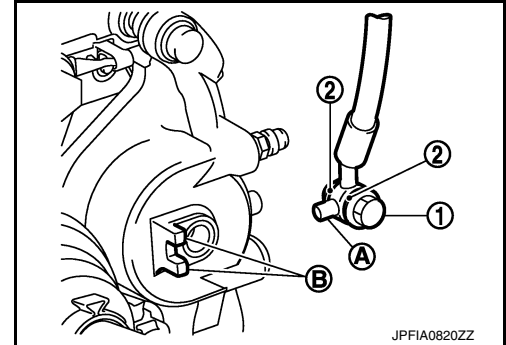

- Refill with new brake fluid and perform air bleeding. Refer to [BR-15, "Bleeding Brake System"](#).

CAUTION:

- **Do not reuse drained brake fluid.**
- **Do not spill or splash brake fluid on the disc brake rotor.**

INSPECTION AFTER INSTALLATION

1. Check drag of front disc brake. If any drag is found, follow procedure described below.
2. Remove brake pads.
3. Using a suitable tool, press the pistons into brake caliper body.
CAUTION:
Do not damage the piston boots.
4. Install brake pads.
5. Depress brake pedal several times.
6. Check drag of front disc brake again. If any drag is found, disassemble brake caliper body. Refer to [BR-47, "Disassembly and Assembly"](#).
7. Burnish contact surfaces after refinishing or replacing disc brake rotors or if a soft pedal occurs at very low mileage. Refer to [BR-17, "DISC BRAKE ROTOR : Brake Burnishing"](#).

DISC BRAKE ROTOR

FRONT DISC BRAKE

< REMOVAL AND INSTALLATION >

DISC BRAKE ROTOR : Exploded View

INFOID:000000012227490

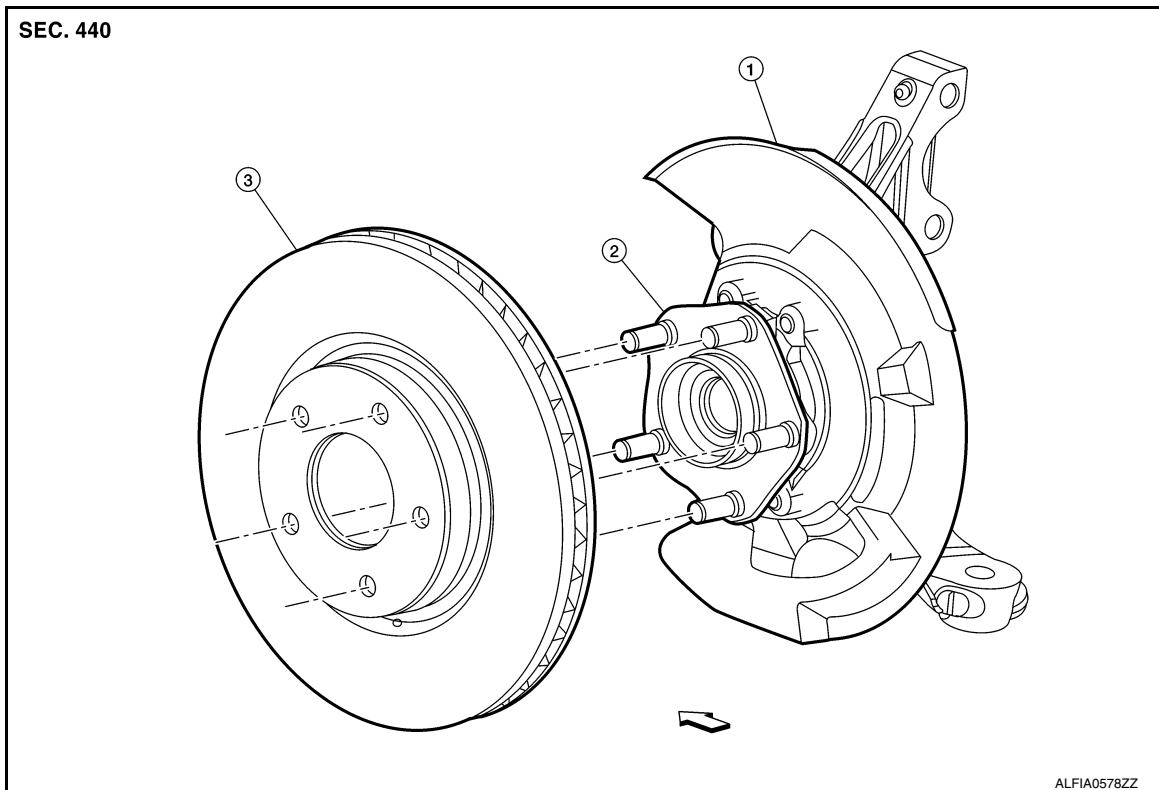

1. Splash guard 2. Front wheel hub and bearing 3. Front disc brake rotor
- ⇐ Front

DISC BRAKE ROTOR : Removal and Installation

INFOID:000000012227491

REMOVAL

1. Remove front wheels and tires using a power tool. Refer to [WT-67, "Removal and Installation"](#).
2. Remove front brake caliper torque member bolts. Leaving brake hose attached, reposition brake caliper aside with wire. Refer to [BR-39, "BRAKE CALIPER ASSEMBLY : Exploded View"](#).
3. Place alignment marks (A) on front disc brake rotor and wheel hub and bearing, then remove front disc brake rotor.

CAUTION:

Do not drop the disc brake rotor.

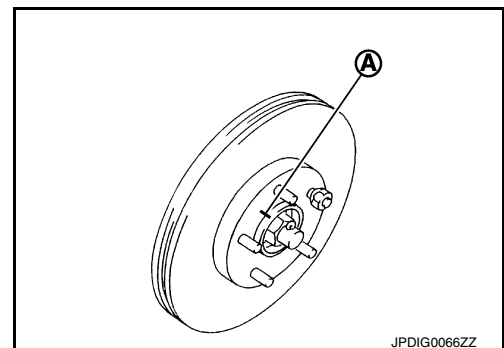

INSTALLATION

Installation is in the reverse order of removal.

A
B
C
D
E
BR
G
H
I
J
K
L
M
N
O
P

REAR DISC BRAKE

< REMOVAL AND INSTALLATION >

REAR DISC BRAKE

BRAKE PAD

BRAKE PAD : Exploded View

INFOID:000000011933975

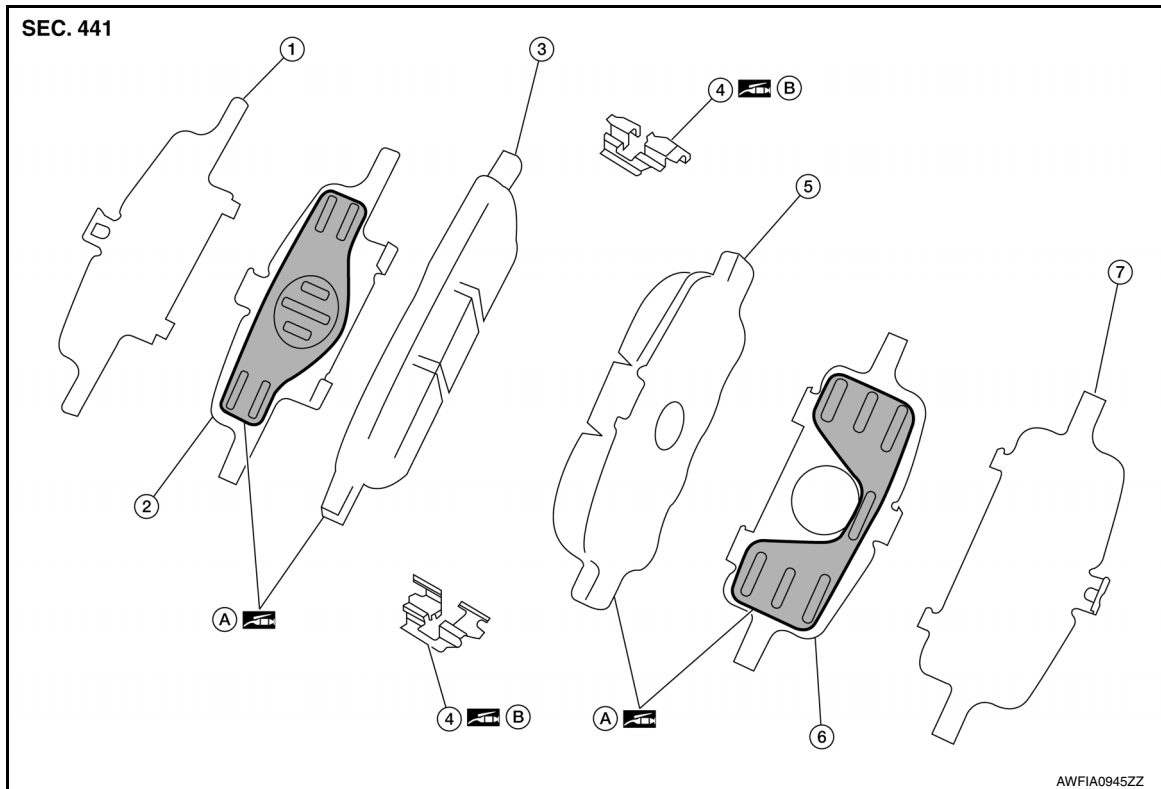

- | | | |
|---------------------|----------------------------|-------------------------|
| 1. Inner shim cover | 2. Inner shim | 3. Inner pad |
| 4. Pad retainer | 5. Outer pad | 6. Outer shim |
| 7. Outer shim cover | A. Molykote AS-880N grease | B. Molykote 7439 grease |

BRAKE PAD : Removal and Installation

INFOID:000000011933976

WARNING:

Clean dust on brake caliper and brake pad with a vacuum dust collector to minimize the hazards of airborne particles or other material.

CAUTION:

- Do not depress the brake pedal while removing the brake pads because the piston may pop out.
- It is not necessary to remove bolts on torque member and brake hose except for disassembly or replacement of brake caliper. For brake pad removal, hang brake caliper with a wire so as not to stretch brake hose.
- If brake fluid or grease adheres to the brake caliper or disc brake rotor, quickly wipe it off.
- Do not reuse drained brake fluid.

REMOVAL

1. Observe brake fluid level in reservoir tank. Partially drain brake fluid if necessary. Refer to [BR-14, "Drain and Refill"](#).

CAUTION:

Do not reuse drained brake fluid.

2. Remove rear wheels and tires using a power tool. Refer to [WT-67, "Removal and Installation"](#).
3. Remove upper and lower slide pin bolts.

NOTE:

Note slide pin orientation during removal. The upper slide pin contains a bushing.

REAR DISC BRAKE

< REMOVAL AND INSTALLATION >

4. Remove brake caliper from torque member. Leaving brake hose attached, reposition brake caliper aside with wire.
5. Remove brake pads, shims, shim covers, pad retainers, and anti-rattle clips from torque member.
CAUTION:
 - Do not reuse the pad retainers and anti-rattle clips.
 - Do not damage the piston boot.
 - Do not drop the brake pads, shims, or the shim covers.
 - Note the position of components during removal to aid with installation.

INSTALLATION

1. Apply Molykote AS-880N grease between inner and outer shims and back of brake pads.
CAUTION:
When installing new brake pads, replace the shims and shim covers.
2. Install inner and outer shims and shim covers to inner pad and outer pad.
CAUTION:
Do not get grease on the inner and outer pad friction surfaces.
3. Apply Molykote 7439 grease (A) to pad retainer and attach pad retainer to torque member.

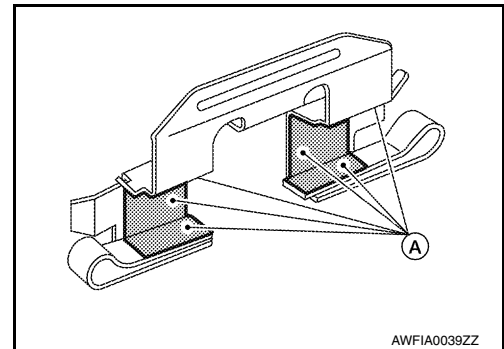

4. Install assembled inner and outer shims, shim covers, pads and anti-rattle clips to torque member.
CAUTION:
Do not get grease on inner and outer pad or rotor friction surfaces.
5. Using a suitable tool, press the pistons into brake caliper.
CAUTION:
Do not damage the piston boot.
6. Install brake caliper to torque member.
7. Install slide pin bolts and tighten to specification.
8. Install rear wheels and tires. Refer to [WT-67, "Removal and Installation"](#).
9. Check brake fluid level and refill as necessary. Refer to [BR-14, "Inspection"](#).

INSPECTION AFTER INSTALLATION

1. Check drag of rear disc brake. If any drag is found, follow procedure described below.
2. Remove brake pads.
3. Using a suitable tool, press pistons into brake caliper body.
CAUTION:
Do not damage the piston boots.
4. Install brake pads.
5. Depress brake pedal several times.
6. Check drag of rear disc brake again. If any drag is found, disassemble brake caliper body.
7. Burnish contact surfaces after refinishing or replacing disc brake rotors or if a soft pedal occurs at very low mileage. Refer to [BR-16, "BRAKE PAD : Brake Burnishing"](#).

BRAKE CALIPER ASSEMBLY

REAR DISC BRAKE

< REMOVAL AND INSTALLATION >

BRAKE CALIPER ASSEMBLY : Exploded View

INFOID:000000011933978

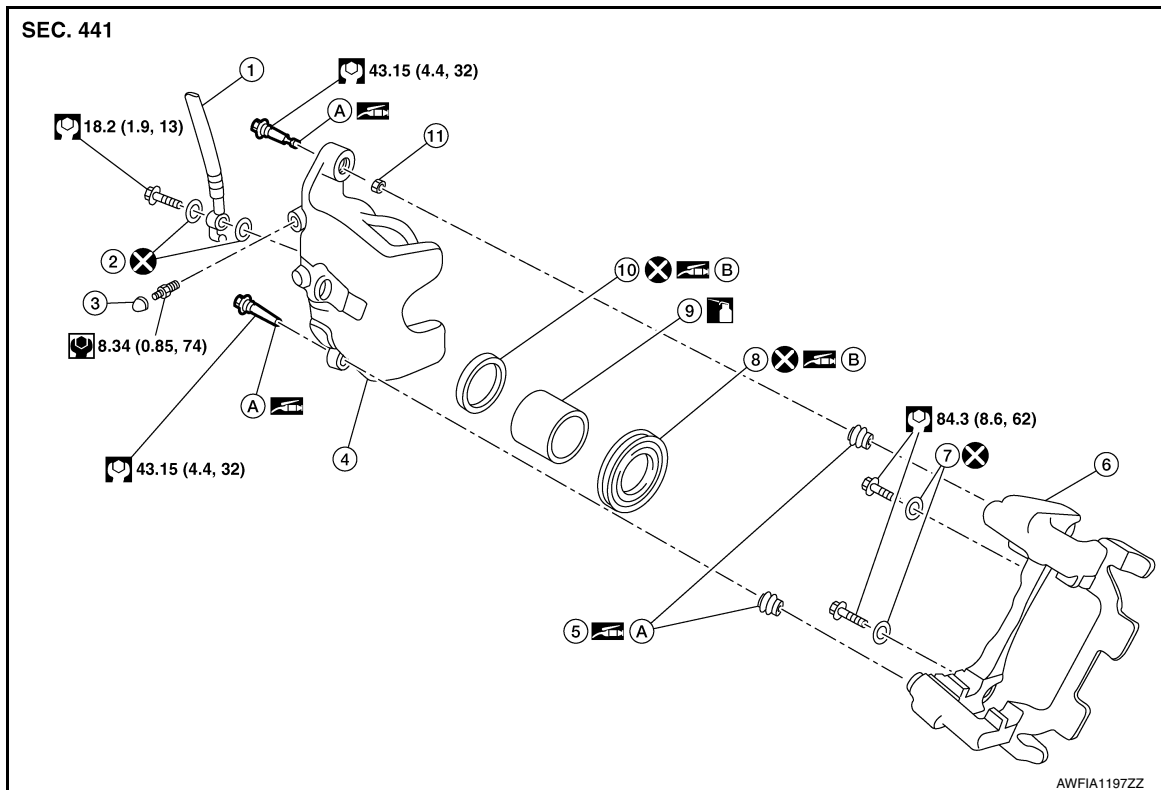

- | | | |
|-----------------------|--------------------------|------------------|
| 1. Brake hose | 2. Copper sealing washer | 3. Bleeder cap |
| 4. Brake caliper body | 5. Sliding pin boot | 6. Torque member |
| 7. Washers | 8. Piston boot | 9. Piston |
| 10. Piston seal | 11. Bushing | |
| A. Niglube Rx-2 | B. Rubber grease | |

 Apply brake fluid.

BRAKE CALIPER ASSEMBLY : Removal and Installation

INFOID:000000011933979

WARNING:

Clean dust on brake caliper and brake pad with a vacuum dust collector to minimize the hazard of airborne particles or other materials.

CAUTION:

- Do not depress the brake pedal.
- Do not spill or splash brake fluid on painted areas; it may cause paint damage. If brake fluid is splashed on painted areas, wash it away with water immediately.
- Do not bend, twist or pull the brake hoses and piping.
- Do not reuse drained brake fluid.

NOTE:

When removing components such as hoses, tubes/lines, etc., cap or plug openings to prevent fluid from spilling.

REMOVAL

1. Observe brake fluid level in reservoir tank. Partially drain brake fluid if necessary. Refer to [BR-14. "Drain and Refill"](#).
2. Remove rear wheels and tires using a power tool. Refer to [WT-67. "Removal and Installation"](#).
3. Remove union bolt and then remove brake hose from brake caliper. Discard copper sealing washers.

CAUTION:

Do not reuse copper sealing washers.

REAR DISC BRAKE

< REMOVAL AND INSTALLATION >

4. Remove slide pin bolts.
NOTE:
Note slide pin orientation during removal. The upper slide pin contains a bushing.
5. Remove brake caliper from torque member.
6. Remove brake pads and shims from torque member.
7. Remove torque member bolts and torque member.

INSTALLATION

Installation is in the reverse order of removal.

- Tighten components to specification. Refer to [BR-39, "BRAKE CALIPER ASSEMBLY : Exploded View"](#).
- Align L-shaped pin on the brake hose in hole in brake caliper, then install brake hose with new copper sealing washers (1) and tighten union bolt (A) to specified torque. Refer to [BR-39, "BRAKE CALIPER ASSEMBLY : Exploded View"](#).

CAUTION:

Do not reuse copper sealing washers.

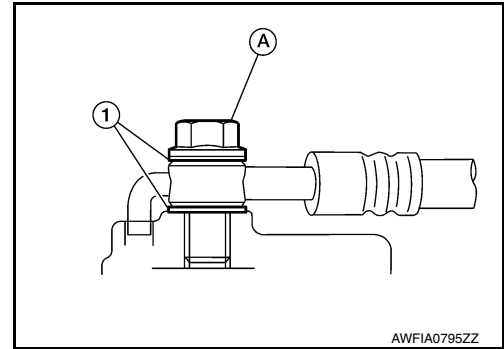

- Refill with new brake fluid and perform air bleeding. Refer to [BR-15, "Bleeding Brake System"](#).

CAUTION:

- **Do not reuse drained brake fluid.**
- **Do not spill or splash brake fluid on the disc brake rotor.**

INSPECTION AFTER INSTALLATION

1. Check drag of rear disc brake. If any drag is found, follow procedure described below.
2. Remove brake pads.
3. Using a suitable tool, press pistons into brake caliper body.
CAUTION:
Do not damage the piston boots.
4. Install brake pads.
5. Depress brake pedal several times.
6. Check drag of rear disc brake again. If any drag is found, disassemble brake caliper body. Refer to [BR-50, "BRAKE CALIPER ASSEMBLY : Disassembly and Assembly"](#).
7. Burnish contact surfaces after refinishing or replacing disc brake rotors or if a soft pedal occurs at very low mileage. Refer to [BR-17, "DISC BRAKE ROTOR : Brake Burnishing"](#).

DISC BRAKE ROTOR

REAR DISC BRAKE

< REMOVAL AND INSTALLATION >

DISC BRAKE ROTOR : Exploded View

INFOID:000000012227503

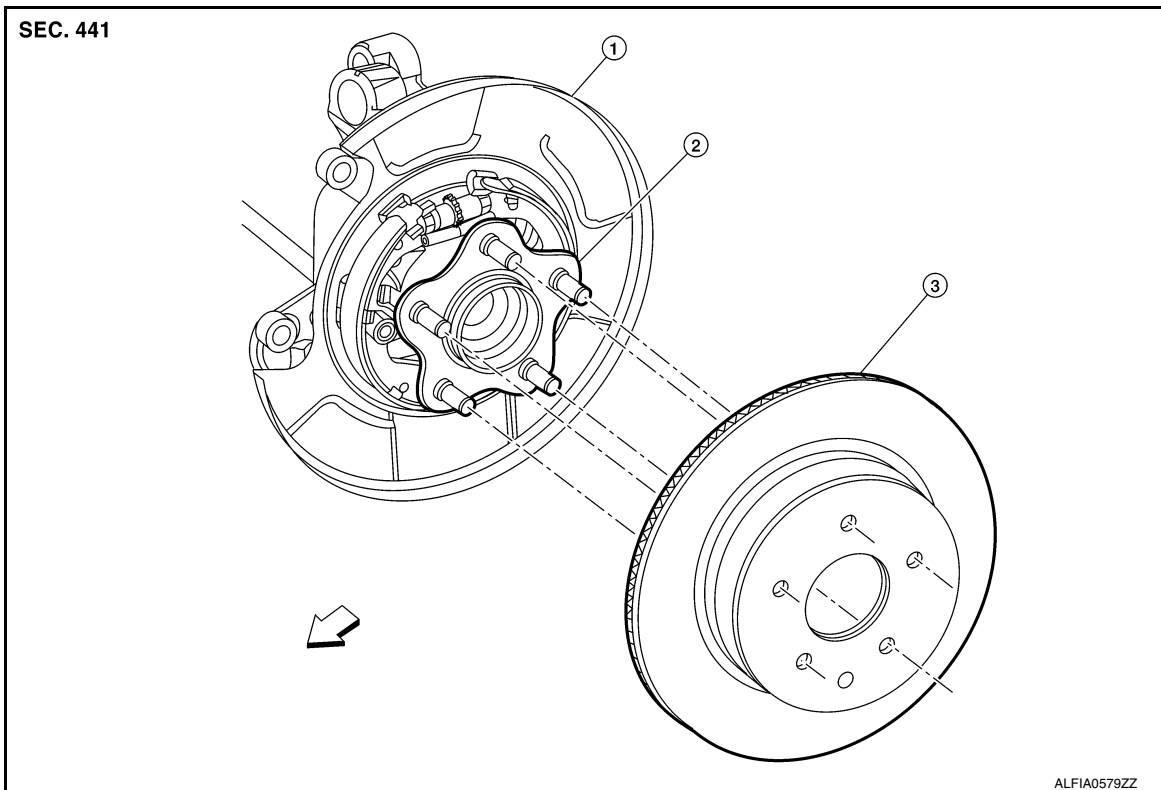

1. Splash guard

2. Rear wheel hub and bearing

3. Rear disc brake rotor

⇐ Front

DISC BRAKE ROTOR : Removal and Installation

INFOID:000000012227504

REMOVAL

1. Remove rear wheels and tires using a power tool. Refer to [WT-67. "Removal and Installation"](#).
2. Remove rear brake caliper torque member bolts. Leaving brake hose attached, reposition brake caliper aside with wire. Refer to [BR-44. "BRAKE CALIPER ASSEMBLY : Exploded View"](#).
3. Place alignment marks (A) on rear disc brake rotor and wheel hub and bearing, then remove rear disc brake rotor.

CAUTION:

Do not drop the disc brake rotor.

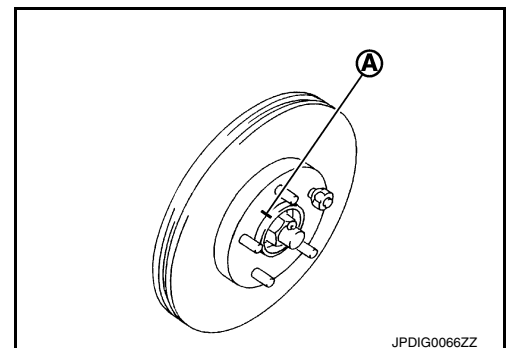

INSTALLATION

Installation is in the reverse order of removal.

FRONT DISC BRAKE

< UNIT DISASSEMBLY AND ASSEMBLY >

UNIT DISASSEMBLY AND ASSEMBLY

FRONT DISC BRAKE

Exploded View

INFOID:000000012227561

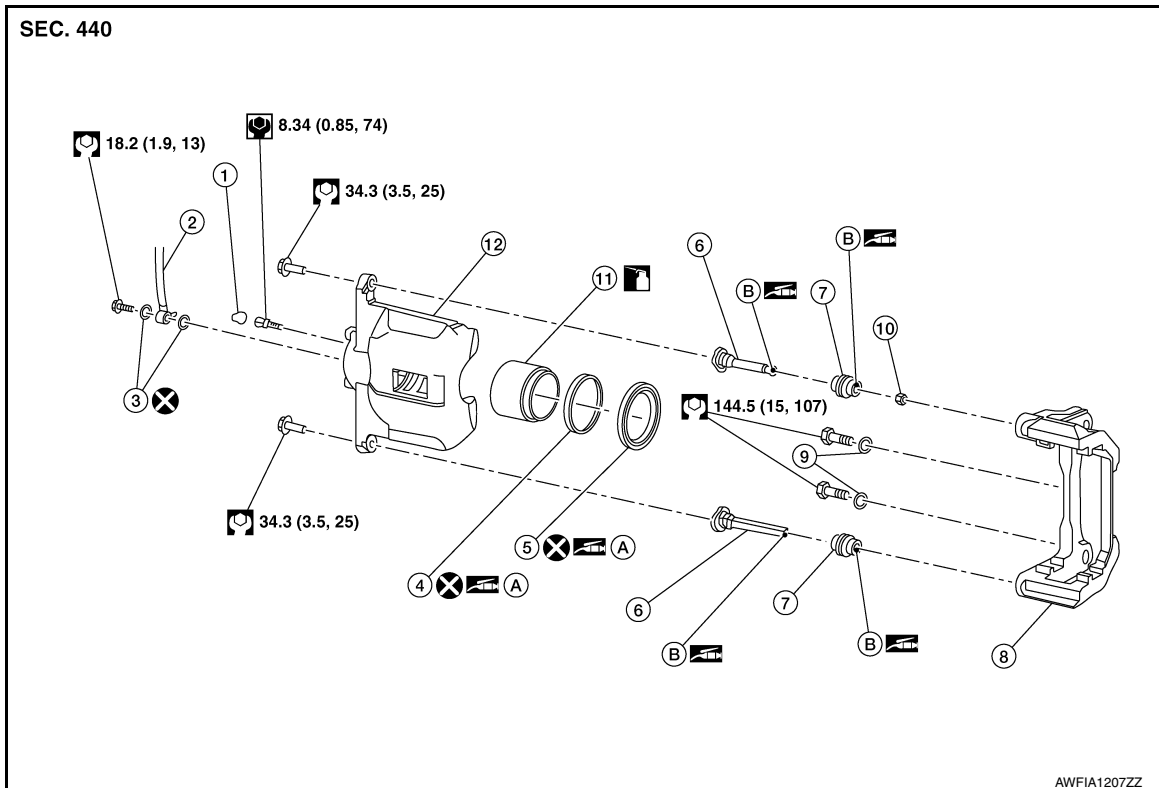

- | | | |
|-------------------|------------------|---------------------------|
| 1. Bleeder cap | 2. Brake hose | 3. Copper sealing washers |
| 4. Piston seal | 5. Piston boot | 6. Slide pin |
| 7. Slide pin boot | 8. Torque member | 9. Washer |
| 10. Bushing | 11. Piston | 12. Brake caliper body |
| A. Rubber grease | B. Niglube Rx-2 | |
-  Apply brake fluid.

Disassembly and Assembly

INFOID:000000012227562

DISASSEMBLY

1. Remove brake caliper from vehicle. Refer to [BR-39. "BRAKE CALIPER ASSEMBLY : Removal and Installation"](#).
2. Remove slide pin boots from torque member.
3. Remove slide pin bushing from slide pin.

FRONT DISC BRAKE

< UNIT DISASSEMBLY AND ASSEMBLY >

4. Place a wooden block in cylinder body and blow air from union bolt hole to remove piston and piston boot.

WARNING:

Do not get fingers caught between pistons and brake caliper body.

CAUTION:

Do not reuse piston boot.

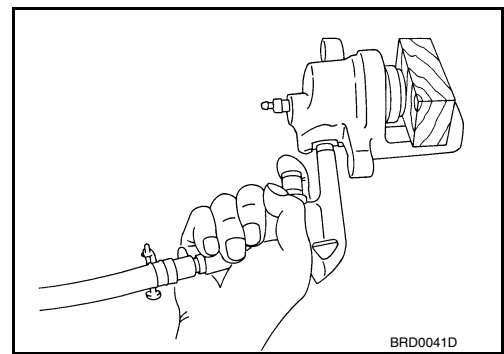

5. Remove piston seal from brake caliper body using a suitable tool.

CAUTION:

- Do not damage cylinder inner wall.
- Do not reuse piston seal.

6. Remove bleeder valve and cap.

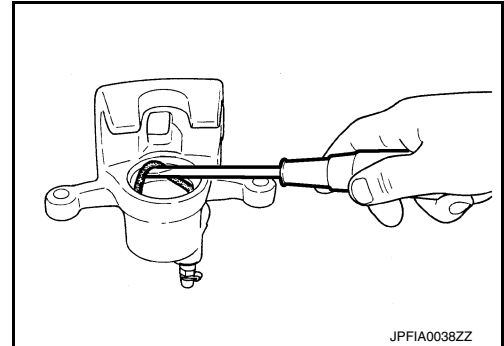

INSPECTION AFTER DISASSEMBLY

Brake Caliper Body

Check inner wall of brake caliper body for rust, wear, cracks or damage. Replace brake caliper body if any abnormal condition is detected.

CAUTION:

Always clean with new brake fluid. Do not clean with mineral oil such as gasoline and light oil.

Torque Member

Check torque member for rust, wear, cracks or damage. Replace torque member if any abnormal condition is detected.

Piston

Check surface of piston for rust, wear, cracks or damage. Replace the piston if any abnormal condition is detected.

CAUTION:

Piston sliding surface is plated. Do not polish with sandpaper.

Slide Pin and Slide Pin Boot

Check slide pins and slide pin boots for rust, wear, cracks or damage. Replace parts if any abnormal condition is detected.

ASSEMBLY

1. Install bleeder valve and cap.
2. Apply rubber grease to piston seal (1), and install it to brake caliper body.

CAUTION:

Do not reuse piston seal.

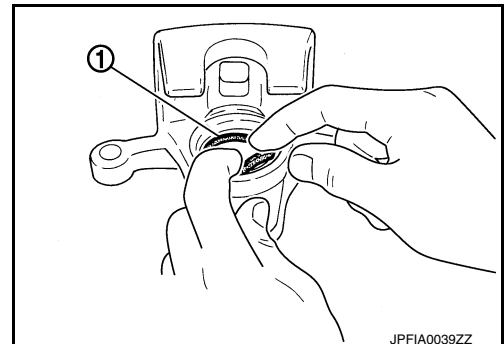

FRONT DISC BRAKE

< UNIT DISASSEMBLY AND ASSEMBLY >

3. Apply rubber grease to piston boot (1). Cover piston (2) end with piston boot, and then install cylinder side lip on piston boot securely into groove on brake caliper body.

CAUTION:

Do not reuse piston boot.

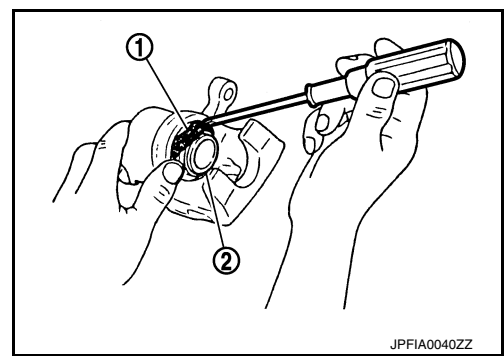

4. Apply brake fluid to piston (1). Push piston into brake caliper body by hand and push piston boot (2) piston side lip into piston groove.

CAUTION:

Press the piston evenly and vary the pressing point to prevent cylinder inner wall from contact.

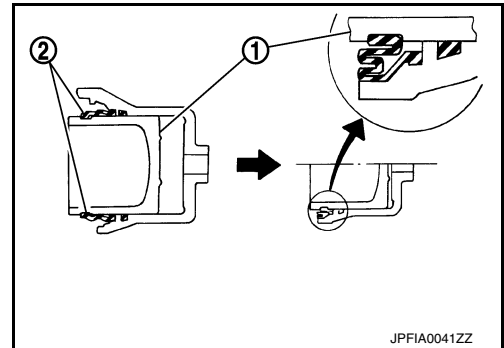

5. Apply Niglube Rx-2 grease to bushing; install bushing to slide pin.
6. Apply Niglube Rx-2 grease to slide pin boots and slide pins.
7. Install slide pin boots and slide pins to torque member.
8. Install the brake caliper to the vehicle. Refer to [BR-39, "BRAKE CALIPER ASSEMBLY : Removal and Installation"](#).

INSPECTION AFTER INSTALLATION

1. Check drag of front disc brake. If any drag is found, follow procedure described below.
2. Remove brake pads.
3. Using a suitable tool, press pistons into brake caliper body.
CAUTION:
Do not damage the piston boots.
4. Install brake pads.
5. Depress brake pedal several times.
6. Check drag of front disc brake again. If any drag is found, disassemble brake caliper body.
7. Burnish contact surfaces after refinishing or replacing disc brake rotors or if a soft pedal occurs at very low mileage. Refer to [BR-17, "DISC BRAKE ROTOR : Brake Burnishing"](#).

REAR DISC BRAKE

< UNIT DISASSEMBLY AND ASSEMBLY >

REAR DISC BRAKE BRAKE CALIPER ASSEMBLY

BRAKE CALIPER ASSEMBLY : Exploded View

INFOID:000000012227567

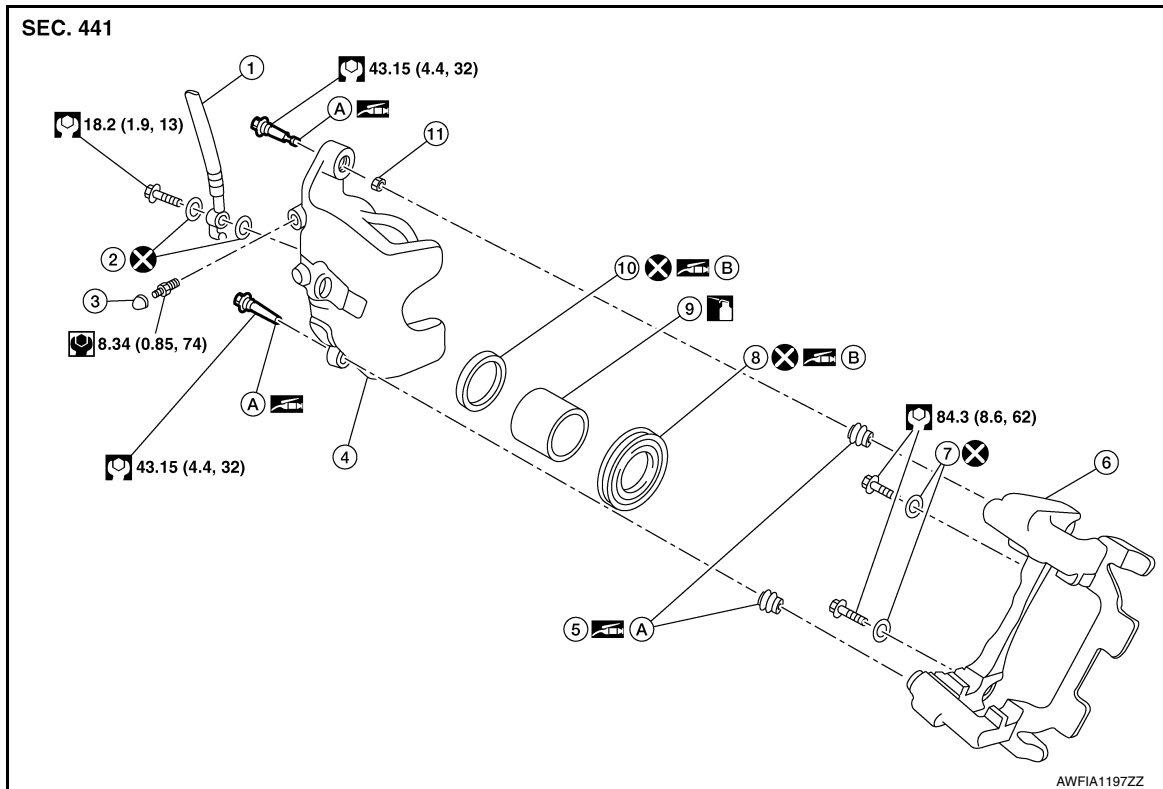

- | | | |
|-----------------------|--------------------------|------------------|
| 1. Brake hose | 2. Copper sealing washer | 3. Bleeder cap |
| 4. Brake caliper body | 5. Sliding pin boot | 6. Torque member |
| 7. Washers | 8. Piston boot | 9. Piston |
| 10. Piston seal | 11. Bushing | |
| A. Nightclub Rx-2 | B. Rubber grease | |
-  Apply brake fluid.

BRAKE CALIPER ASSEMBLY : Disassembly and Assembly

INFOID:000000012227568

DISASSEMBLY

1. Remove brake caliper from vehicle. Refer to [BR-44. "BRAKE CALIPER ASSEMBLY : Removal and Installation"](#).
2. Remove slide pin boots from torque member.
3. Remove slide pin bushing from slide pin.
4. Place a wooden block in cylinder body and blow air from union bolt hole to remove piston and piston boot.

WARNING:

Do not get fingers caught between pistons and brake caliper body.

CAUTION:

Do not reuse piston boot.

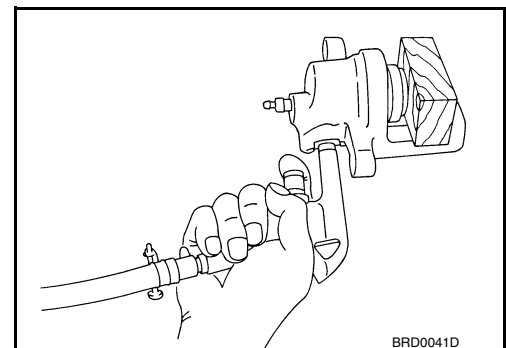

REAR DISC BRAKE

< UNIT DISASSEMBLY AND ASSEMBLY >

- Remove piston seal from brake caliper body using a suitable tool.
CAUTION:
 - Do not damage cylinder inner wall.
 - Do not reuse piston seal.
- Remove bleeder valve and cap.

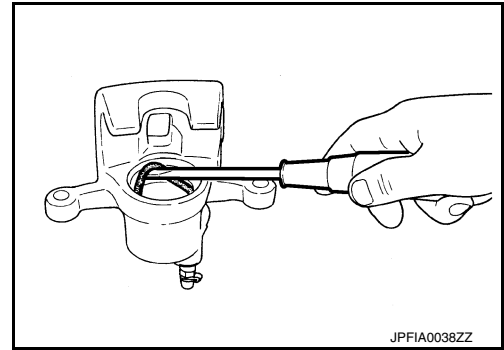

INSPECTION AFTER DISASSEMBLY

Brake Caliper Body

Check inner wall of the brake caliper body for rust, wear, cracks or damage. Replace brake caliper body if any abnormal condition is detected.

CAUTION:

Always clean with new brake fluid. Do not clean with mineral oil such as gasoline and light oil.

Torque Member

Check torque member for rust, wear, cracks or damage. Replace torque member if any abnormal condition is detected.

Piston

Check surface of piston for rust, wear, cracks or damage. Replace piston if any abnormal condition is detected.

CAUTION:

Piston sliding surface is plated. Do not polish with sandpaper.

Slide Pin and Slide Pin Boot

Check slide pins and slide pin boots for rust, wear, cracks or damage. Replace parts if any abnormal condition is detected.

ASSEMBLY

- Install bleeder valve and cap.
- Apply rubber grease to piston seal (1), and install it to brake caliper body.

CAUTION:

Do not reuse piston seal.

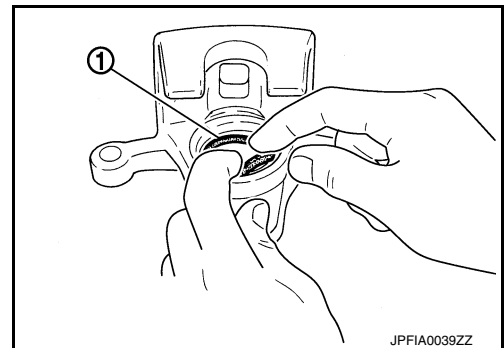

- Apply rubber grease to piston boot (1). Cover piston (2) end with piston boot, and then install cylinder side lip on piston boot securely into groove on brake caliper body.

CAUTION:

Do not reuse piston boot.

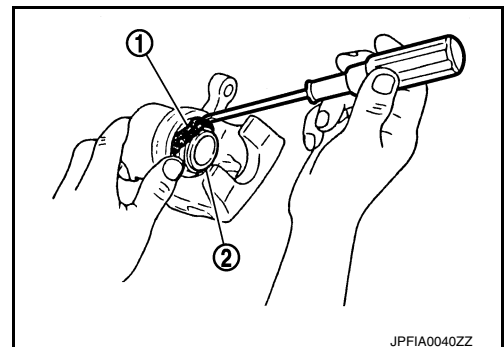

A
B
C
D
E
BR
G
H
I
J
K
L
M
N
O
P

REAR DISC BRAKE

< UNIT DISASSEMBLY AND ASSEMBLY >

4. Apply brake fluid to piston (1). Push piston into brake caliper body by hand and push piston boot (2) piston side lip into piston groove.

CAUTION:

Press piston evenly and vary pressing points to prevent cylinder inner wall from contact.

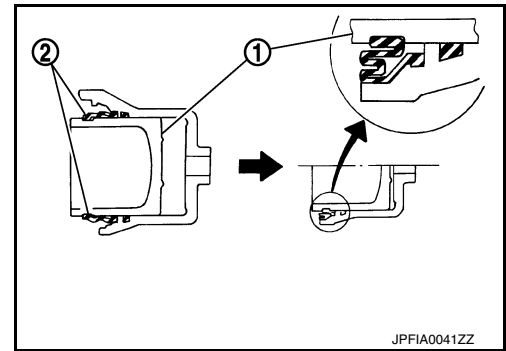

5. Apply Niglube Rx-2 grease to bushing; install bushing to slide pin.
6. Apply Niglube Rx-2 grease to slide pin boots and slide pins.
7. Install slide pin boots and slide pins to torque member.
8. Install the brake caliper to vehicle. Refer to [BR-44, "BRAKE CALIPER ASSEMBLY : Removal and Installation"](#).

INSPECTION AFTER INSTALLATION

1. Check drag of rear disc brake. If any drag is found, follow procedure described below.
2. Remove brake pads.
3. Using a suitable tool, press the pistons into brake caliper body.
CAUTION:
Do not damage the piston boots.
4. Install brake pads.
5. Depress brake pedal several times.
6. Check drag of rear disc brake again. If any drag is found, disassemble brake caliper body.
7. Burnish contact surfaces after refinishing or replacing disc brake rotors or if a soft pedal occurs at very low mileage. Refer to [BR-19, "DISC BRAKE ROTOR : Brake Burnishing"](#).

SERVICE DATA AND SPECIFICATIONS (SDS)

< SERVICE DATA AND SPECIFICATIONS (SDS)

SERVICE DATA AND SPECIFICATIONS (SDS)

SERVICE DATA AND SPECIFICATIONS (SDS)

General Specifications

INFOID:0000000011933982

Unit: mm (in)

Front brake	Cylinder bore diameter	57.15 (2.250)
	Pad length × width × thickness	123.6 × 53.5 × 11.0 (4.866 × 2.106 × 0.433)
	Rotor outer diameter × thickness	320 × 28 (12.598 × 1.102)
Rear brake	Cylinder bore diameter	34.93 (1.375)
	Pad length × width × thickness	83.0 × 33.0 × 8.5 (3.268 × 1.299 × 0.335)
	Rotor outer diameter × thickness	308 × 16 (12.126 × 0.630)
Master cylinder	Cylinder bore diameter	25.4 (1.000)
Control valve	Valve type	Electric brake force distribution
Recommended brake fluid		Refer to MA-16. "FOR USA AND CANADA : Fluids and Lubricants" (United States and Canada) or MA-17. "FOR MEXICO : Fluids and Lubricants" (Mexico)

Brake Pedal

INFOID:0000000011933983

Unit: mm (in)

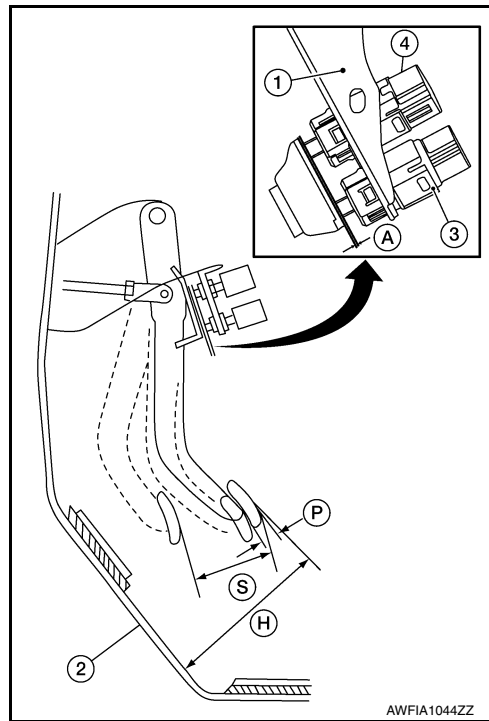

Item	Standard
Brake pedal height (H) from lower dash (2)	181.4 – 191.4 (7.14 – 7.54)
Clearance (A) between brake pedal bracket, stop lamp switch (3) and brake pedal position switch (4) contact ends	0.74 – 1.96 (0.0291 – 0.0772)
Brake pedal full stroke (S)	135.3 (5.33)
Brake pedal play (P)	—

SERVICE DATA AND SPECIFICATIONS (SDS)

< SERVICE DATA AND SPECIFICATIONS (SDS)

Unit: mm (in)

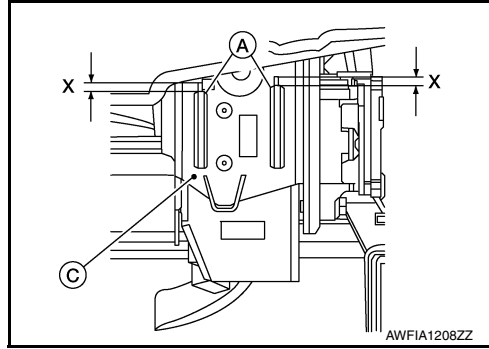

Overlap distance (X) between sub-bracket (A) and slide plate (C)	5.5 ± 0.5 (0.22 ± 0.02)
--	-------------------------

Check Valve - Vacuum Hose Without Check Valve

INFOID:000000011933984

Vacuum leakage [at vacuum of -66.7 kPa (-500 mmHg, -19.69 inHg)]	Within 1.3 kPa (10 mmHg, 0.39 inHg) of vacuum for 15 seconds
---	--

Check Valve - Vacuum Hose With Check Valve

INFOID:000000013088796

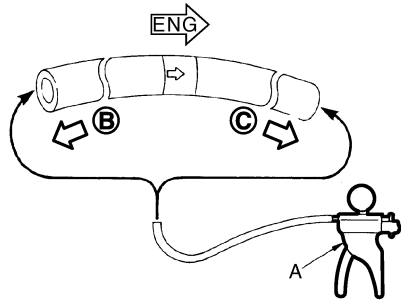

When suitable tool (A) is connected to booster side (B)	1.3 kPa (10 mmHg, 0.39 inHg) maximum vacuum loss for 15 seconds at vacuum of -26.6 ± 1.3 kPa (200 ± 1.0 mmHg, -7.87 ± 0.04 inHg)
When suitable tool (A) is connected to engine side (C)	No vacuum should exist.

Brake Booster

INFOID:000000011933985

Unit: mm (in)

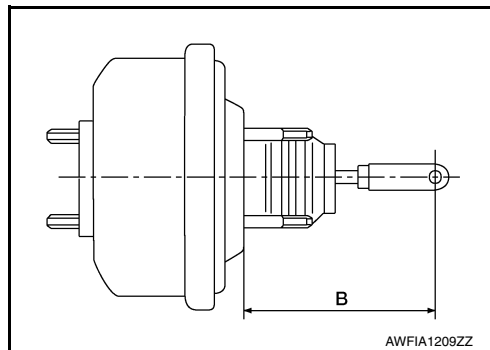

Input rod installation standard dimension (B)	125.0 ± 0.5 (4.92 ± 0.02)
---	---------------------------

SERVICE DATA AND SPECIFICATIONS (SDS)

< SERVICE DATA AND SPECIFICATIONS (SDS)

Front Disc Brake

INFOID:0000000011933986

Unit: mm (in)

Item		Limit
Brake pad	Standard thickness (new)	11.0 (0.433)
	Minimum thickness	2.0 (0.079)
Disc rotor	Standard thickness (new)	28.0 (1.102)
	Minimum thickness	26.0 (1.024)
	Thickness variation (measured at 8 positions)*	0.015 (0.0006)
	Maximum runout (with it attached to the vehicle)	0.040 (0.0016)

* To check if rotor imbalance, rotor runout or rotor deformation exists.

Rear Disc Brake

INFOID:0000000011933987

Unit: mm (in)

Item		Limit
Brake pad	Standard thickness (new)	8.5 (0.335)
	Minimum thickness	1.0 (0.039)
Disc rotor	Standard thickness (new)	16.0 (0.630)
	Minimum thickness	14.0 (0.551)
	Thickness variation (measured at 8 positions)*	0.015 (0.0006)
	Maximum runout (with it attached to the vehicle)	0.05 (0.0020)

* To check if rotor imbalance, rotor runout or rotor deformation exists.